

The Tata Power Company Ltd		OPEN TENDER NOTIFICATION
Tender Reference: CC24VJS050		Document Date: 1st Jan 2024

The Tata Power Company Limited Invites Tender through E-Tender Two-Part Bidding Process from interested bidders for the following package: -

A. Summary of the tendered package:

Sr. No.	Description	Tender Reference no.	Bid Guarantee Fee / EMD (Rs.)	Tender Fee (Rs.)	Last Date and Time for payment of Tender Participation fee
For the following package please send mail to Mr. Vinayak Shinde (vinayak.shinde@tatapower.com) with copy to Mr. Rameshkumar P N (pnramesh@tatapower.com)					
1.	Corrigendum to Tender issued vide advertisement published dtd. 20th Dec 2023 - Out Line Agreement for 1 year for procurement of Feeder Pillars & Mini Pillars for Mumbai Distribution	CC24VJS050	1,50,000/-	2,000 /-	8th Jan 2024

B. Procedure to Participate in Tender.

Following steps to be done before “Last date and time for Payment of Tender Participation Fee” as mentioned above

1. Non-Refundable Tender Fee, as indicated in table above, to be submitted in the form of Direct deposit in the following bank account and submit the receipt along with a covering letter clearly indicating the Tender Reference number –

Beneficiary Name – The Tata Power Co. Ltd.

Bank Name – HDFC Bank Ltd.

Branch Name – Fort Branch, Mumbai

Address – Maneckji Wadia Building, Nanik Motwani Marg, Fort, Mumbai 400023.

Branch Code – 60

Bank & Branch Code – 400240015

Account No – 00600110000763

Account type – CC

IFSC Code – HDFC0000060

2. Eligible and Interested Bidders to submit duly signed and stamped letter on Bidder's letterhead indicating

Tender Enquiry number

Name of authorized person

Contact number

The Tata Power Company Ltd		OPEN TENDER NOTIFICATION
Tender Reference: CC24VJS050		Document Date: 1 st Jan 2024

e-mail id

Details of submission of Tender Participation Fee

E-mail with necessary attachment of 1 and 2 above to be send to vinayak.shinde@tatapower.com with copy to pnramesh@tatapower.com before “Last date and time for Payment of Tender Participation Fee”

Interested bidders to submit Tender Participation Fee and Authorization Letter before Last date and time as indicated above after which link from Tata Power E-Tender system (Ariba) will be shared for further communication and bid submission.

Please note all future correspondence regarding the tender, bid submission, bid submission date extension, Pre-bid query etc. will happen only through Tata Power E-Tender system (Ariba).

No e-mail or verbal correspondence will be responded. All communication will be done strictly with the bidder who have done the above step to participate in the Tender.

Also it may be strictly noted that once date of “Last date and time for Payment of Tender Participation Fee” is lapsed no Bidder will be sent link from Tata Power E-Tender System (Ariba). Without this link vendor will not be able to participate in the tender. Any last moment request to participate in tender will not be entertained.

Any payment of Tender Participation Fee by Bidder who have not done the pre-requisite will not be refunded.

Also all future corrigendum’s to the said tender will be informed on Tender section on website <https://www.tatapower.com> only.

Revised Qualification Criteria

S.No.	Description	Qualifying Criteria	Evaluation Documents Required
1	Infrastructure	Bidder must be an OEM of Equipment with manufacturing facility / assembly in India. The bidder must have in-house routine and acceptance testing facilities for acceptance as per relevant IS/IEC	Self-undertaking to be submitted in this regard. TATA Power reserves the right to inspect the said manufacturing facility as a proof of compliance to this parameter.
2	Supply and Experience	The bidder must have supplied for same or higher size and voltage a) minimum of 200 nos during last 5 years or b) A single order of 100 nos or c) Two orders of 60 nos last 5 years. Indian Subsidiaries of global companies having plant in India are also eligible to bid if the qualification requirements stated above are	Purchase Order Copies and Completion Certificates. Self-undertaking to be submitted in this regard. TATA Power reserves the right to inspect the said

The Tata Power Company Ltd		<i>OPEN TENDER NOTIFICATION</i>
<i>Tender Reference: CC24VJS050</i>		<i>Document Date: 1st Jan 2024</i>

S.No.	Description	Qualifying Criteria	Evaluation Documents Required
		met independently or in combination with the parent company. Declaration from parent company needs to be submitted.	manufacturing facility as a proof of compliance to this parameter.
	Type Test	<p>The bidder shall submit Type test reports obtained from NABL / International Accredited Lab for the equipment / material offered. The type tests should have been conducted on the equipment / material of the same design meeting IS guidelines.</p> <p>The type tests should have been conducted within 5 years prior to the date of bid opening. Time period for type test can be extended by another 5 years as a special case if there is no change in design / material of construction (MOC).</p> <p>In case the type test reports furnished are not for the quoted equipment / material but for the equipment / material with higher voltage class and/or different capacity, then type test shall be carried out for the offered equipment / material from NABL / International Accredited Lab without any cost implication to the owner and the Type Test reports shall be submitted before dispatch of the equipment / material and within 120 days of outline agreement.</p>	<p>Type Test Report.</p> <p>Undertaking that there is no change in design / material of construction (MOC) if Type Test Report older than 5 years.</p> <p>Undertaking that type test shall be carried out for the offered equipment / material from NABL / International Accredited Lab without any cost implication to the owner and Type Test reports shall be submitted before dispatch of the equipment / material and within 120 days of outline agreement.</p> <p>Undertaking that there is no change in design / material of construction (MOC) if Type Test Report older than 5 years.</p>
5	Commercial Capability	Average Annual turnover of the bidder for last three years shall not be less than Rs 3 Crs	Copy of audited P&L Account to be submitted in this regard (with UDIN No)

The Tata Power Company Ltd		<i>OPEN TENDER NOTIFICATION</i>
<i>Tender Reference: CC24VJS050</i>		<i>Document Date: 1st Jan 2024</i>

S.No.	Description	Qualifying Criteria	Evaluation Documents Required
6	Performance	The bidder should have performance certificates for 2 year satisfactory performance from at least 2 reputed Distribution Utilities for equipments of similar or higher rating. The work against these issued certificates should be completed in last seven years from the date of bid submission. In case the bidder has a previous association with any of Tata Power Groups for similar products and services, the performance feedback for that bidder by Tata Power User Group shall only be considered irrespective of performance certificates issued by any third organization.	Supply List & Performance Certificates from the utilities

Revised Price Bid format

Sr. no.	Material / Service Short Text (as per SAP)	Quantity	UoM	Unit Rate (Basic)	Total
1	FEEDER, COMPACT FDR PLR 2 IC,630A&6 OG,CO	500	Nos		-
2	PILLAR MINI 415V W/400A BUS BAR F/CABLE	80	Nos		-
3	PANEL, MINI PILLAR WITH FUSES,	50	Nos		-
4	Feeder pillar type test charges	1	Nos		-
	Sub Total				-
	GST @18%				-
	Total with taxes				-

Summary of Changes

- 1 Date extension of submission of Expression of Interest till 8th Jan 2024.
- 2 Revised PQR issued.
- 3 Price Bid format revised for addition of type test charges on one unit.
- 4 Technical specifications added at the end of this document.

The original tender document is reproduced below.

The Tata Power Company Ltd		<i>OPEN TENDER NOTIFICATION</i>
<i>Tender Reference: CC24VJS050</i>		<i>Document Date: 1st Jan 2024</i>

OPEN TENDER NOTIFICATION

FOR

Out Line Agreement for 1 year for procurement of Feeder Pillars & Mini Pillars for Mumbai Distribution.

**The Tata Power Company Limited (Tata Power)
Smart Center of Procurement Excellence, 2nd Floor,
Sahar Receiving Station, Near Hotel Leela,
Sahar Airport Road, Andheri East, Mumbai-400059**

The Tata Power Company Ltd		OPEN TENDER NOTIFICATION
Tender Reference: CC24VJS050		Document Date: 1 st Jan 2024

Section A : Tender Notice including Instruction to Bidders

1. Tender Details

1.1 Key Tender Specific Details

Reference Number	CC24VJS050
Description	Out Line Agreement for 1 year for procurement of Feeder Pillars & Mini Pillars for Mumbai Distribution
Type of Tender	Out Line Agreement
Estimated Period	One Year
Tender Fee	Rs 2000/-
Earnest Money Deposit (EMD)	Rs 1,50,000/- Rs. One Lakh Fifty thousand Only PLEASE NOT THAT IT IS MANDATORY TO SUBMIT EMD IN BANK GUARANTEE FORMAT ONLY
Price Basis	Firm Basis
Executive Handling this Tender*	Name: Mr. Vinayak Shinde E-Mail ID: vinayak.shinde@tatapower.com
Technical Query *	Name: Mr. Ajay Potdar E-Mail ID: avpotdar@tatapower.com

*You may contact the above personnel from Monday to Friday during office hours only.

The Tata Power Company Ltd		OPEN TENDER NOTIFICATION
Tender Reference: CC24VJS050		Document Date: 1 st Jan 2024

1.2 Calendar of Events

(a)	Payment of Tender Fee and Submission of letter nominating authorized person by Interested Bidder indicating their intent to Buy Tender	Till 29 th December 2023 , up to 1500 Hours
(b)	Access to Tender Documents through E-Tender system to authorized person of Interested Bidder	29 th December 2023
(c)	Last Date of receipt of pre-bid queries, if any.	By 5 th January 2024, 1500 Hrs.
(d)	Last Date of Posting Consolidated replies to all the pre-bid queries as received	12 th January 2024
(e)	Last date and time of receipt of Bids	19 th January 2024 by 15:00 Hrs.*

Note:- * These date and time are as planned and tentative. In case of change the same shall be intimated to Authorized Person of Interested Bidder through E-Tender System.

Please note post submission of Bids relevant communication will be done with Authorized Person of Interested Bidder through E-Tender System

1.3 Mandatory documents required along with the Bid

- 1.3.1 Bid Guarantee Fee (EMD) of requisite value and validity. PLEASE NOTE THAT BID GUARANTEE ONLY IN FORM OF BANK GUARANTEE WILL BE ACCEPTED.
- 1.3.2 Requisite Documents to ascertain fulfilling of Technical and Commercial Pre-Qualification Requirement as detailed in Tender Enquiry.
- 1.3.3 Technical Submission including Drawings, Type Test details etc as detailed in Technical Specification.
- 1.3.4 Required Commercial Submission as detailed in Tender Document
- 1.3.5 Technical and Commercial Clarification and Deviations as per the format attached in the Tender Enquiry
- 1.3.6 Proper authorization letter to sign the tender and participate in Tata Power E-Tender system on the behalf of bidder.
- 1.3.7 **For vendor not registered with Tata Power, Duly filled Vendor Registration form with all supporting documents is mandatory to participate in the Tender.**

Please note that in absence of any of the above documents, the bid submitted by a bidder shall be liable for rejection.

Also please note that whenever editable format are shared it is requested that data be filled in relevant cells. No formatting or addition / deletion of rows / columns to be done. Wherever editable Excel submission are requested the file should be free from references, macros etc.

The Tata Power Company Ltd		<i>OPEN TENDER NOTIFICATION</i>
<i>Tender Reference: CC24VJS050</i>		<i>Document Date: 1st Jan 2024</i>

Checklist of Document Submission

Stage of Tendering	Document	Type of Format	Mode of submission
Before last date of Pre-Bid Query	Query / Clarification / Deviation (QCD) Format. (F1) Technical and Commercial	Editable Excel Format	Through message in E-tender system
Bid Submission Envelope 1 (First Part)	Earnest Money Deposit	Original Bank Guarantee	In Sealed Envelope
Bid Submission Envelope 2 (Second Part)	Documents to be uploaded in Ariba only. In case of multiple files, a zipped folder can be attached for the same (size limit of 100MB per zipped file)		
To be submitted Under Tab 2.1 in Ariba	Duly filled PQR and supporting documents		
	Duly filled PQR format	Editable Excel Format	E-Tender System
	Backup documents for Technical and Commercial PQR	Signed and Scanned documents	E-Tender System
To be submitted under Tab 2.2 in Ariba	Technical Submission and Supporting Documents		
	Duly filled Unpriced Bid Format. Signed copy of Technical Specifications indicating your acceptance of the same	Signed and scanned copy of document	E-Tender System
To be submitted under Tab 2.3 in Ariba	Commercial Submission and supporting document		

The Tata Power Company Ltd		<i>OPEN TENDER NOTIFICATION</i>
<i>Tender Reference: CC24VJS050</i>		<i>Document Date: 1st Jan 2024</i>

	Letter of Undertaking (FOR VENDORS NOT REGISTERED WITH TATA POWER)	Scanned Copy of letter of undertaking duly filled, stamped and signed	E-Tender System
	E-auction Undertaking form	Scanned Copy of letter of undertaking duly filled, stamped and signed	E-Tender System
Bid Submission Envelope 3 (Third Part)	Duly filled Priced Bid Format	Hard copy in original duly signed and stamped	Sealed Envelope
	Duly filled Priced Bid Format	To be entered in E-Tender System	E-Tender System

1.4 Deviation from Tender

Normally, the deviations to tender terms are not admissible and the bids with deviation are liable for rejection. Hence, the bidders are advised to refrain from taking any deviations on this Tender. Still in case of any deviations, all such deviations shall be set out by the Bidders, clause by clause in the Query / Clarification / Deviation (QCD) Format. Deviations have to be mandatorily submitted in editable Excel sheet.

Technical or Commercial Deviation should be mentioned in Deviation Format only. Deviation in any other document or Format will not be considered.

1.5 Right of Acceptance/Rejection

1.5.1 Bids are liable for rejection in absence of following:-

1.5.2 Mandatory Documents as listed in 1.3 above

1.5.3 Price Bid as per the Price Schedule mentioned in Tender Document

1.5.4 Receipt of Bid and Response to queries within the due date and time

Tata Power reserves the right to accept/reject any or all the bids without assigning any reason thereof.

The Tata Power Company Ltd		<i>OPEN TENDER NOTIFICATION</i>
<i>Tender Reference: CC24VJS050</i>		<i>Document Date: 1st Jan 2024</i>

1.6 Qualification Criteria

S.No.	Description	Qualifying Criteria	Evaluation Documents Required
1	Infrastructure	Bidder must be an OEM of Equipment with manufacturing facility / assembly in India. The bidder must have in-house routine and acceptance testing facilities for acceptance as per relevant IS/IEC	Self-undertaking to be submitted in this regard. TATA Power reserves the right to inspect the said manufacturing facility as a proof of compliance to this parameter.
2	Supply and Experience	<p>The bidder must have supplied for same or higher size and voltage</p> <p>a) A minimum of 630 nos during last 3 years or b) A single order of 315 nos or c) Two orders of 190 nos last 3 years.</p> <p>Indian Subsidiaries of global companies having plant in India are also eligible to bid if the qualification requirements stated above are met independently or in combination with the parent company. Declaration from parent company needs to be submitted.</p>	<p>Purchase Order Copies and Completion Certificates.</p> <p>Self-undertaking to be submitted in this regard. TATA Power reserves the right to inspect the said manufacturing facility as a proof of compliance to this parameter.</p>

The Tata Power Company Ltd		<i>OPEN TENDER NOTIFICATION</i>
<i>Tender Reference: CC24VJS050</i>		<i>Document Date: 1st Jan 2024</i>

S.No.	Description	Qualifying Criteria	Evaluation Documents Required
	Type Test	<p>The bidder shall submit Type test reports obtained from CPRI/ERDA/ International Accredited Lab for the equipment / material offered. The type tests should have been conducted on the equipment / material of the same design meeting IS guidelines.</p> <p>The type tests should have been conducted within 5 years prior to the date of bid opening. Time period for type test can be extended by another 5 years as a special case if there is no change in design / material of construction (MOC).</p> <p>In case the type test reports furnished are not for the quoted equipment / material but for the equipment / material with higher voltage class and/or different capacity, then type test shall be carried out for the offered equipment / material from CPRI /ERDA/ International Accredited Lab without any cost implication to the owner and the Type Test reports shall be submitted before dispatch of the equipment / material and within 120 days of outline agreement.</p>	<p>Type Test Report.</p> <p>Undertaking that there is no change in design / material of construction (MOC) if Type Test Report older than 5 years.</p> <p>Undertaking that type test shall be carried out for the offered equipment / material from CPRI / ERDA/ International Accredited Lab without any cost implication to the owner and Type Test reports shall be submitted before dispatch of the equipment / material and within 120 days of outline agreement. Undertaking that there is no change in design / material of construction (MOC) if Type Test Report older than 5 years.</p>
5	Commercial Capability	Average Annual turnover of the bidder for last three years shall not be less than Rs 3 Crs	Copy of audited P&L Account to be submitted in this regard (with UDIN No)
6	Performance	The bidder should have performance certificates for 2 year satisfactory performance from at least 2 reputed Distribution Utilities for equipments of similar or higher rating. The work against these issued certificates should be completed in last seven years from the date of bid submission. In case the bidder has a previous association with any of Tata Power Groups for similar products and services, the performance feedback for that bidder by Tata Power User Group shall only be considered irrespective of performance certificates issued by any third organization.	Supply List & Performance Certificates from the utilities

The Tata Power Company Ltd	 TATA TATA POWER	<i>OPEN TENDER NOTIFICATION</i>
<i>Tender Reference: CC24VJS050</i>		<i>Document Date: 1st Jan 2024</i>

1.7 Pre-Bid Queries

Technical or Commercial Pre-Bid Queries if any has to be sent through message in E-Tender System. Pre-Bid Query has to be sent only in the Query / Clarification / Deviation (QCD) Format. Pre-Bid Queries sent in any other format or send through any other communication channel will not be accepted and answered. Pre-Bid Query have to be sent in the stipulated timeline as defined in the Tender Document. No Pre-Bid Query will be accepted after the due time and date as specified as "Last Date of receipt of pre-bid queries, if any"

1.8 Marketing Integrity

We have a fair and competitive marketplace. The rules for bidders are outlined in the General Condition of Contracts and other parts of Tender Documents. Bidders must agree to these rules prior to participating. In addition to other remedies available, Tata Power reserves the right to exclude a bidder from participating in future markets due to the bidder's violation of any of the rules or obligations contained in the General Condition of Contracts or other part of the Tender Documents. A bidder who violates the market place rules or engages in behavior that disrupts the fair execution of the marketplace, may result in restriction of a bidder from further participation in the marketplace for a length of time, depending upon the seriousness of the violation. Examples of violations include, but are not limited to:

- Failure to honor prices submitted to the marketplace
- Breach of terms as published in TENDER
- Submit irrelevant documents or frequently cases of missing documents as part of compliance to Qualifying, Technical or Commercial Requirements causing unnecessary delay in Tender Evaluation

1.9 Supplier Confidentiality

All information contained in this tender is confidential and shall not be disclosed, published or advertised in any manner without written authorization from Tata Power. This includes all bidding information submitted to Tata Power. All tender documents remain the property of Tata Power and all suppliers are required to return these documents to Tata Power upon request. Suppliers who do not honor these confidentiality provisions will be excluded from participating in future bidding events.

1.10 Payment Terms

100% payment shall be made within **60 days** from the receipt and acceptance of the material at the Consignee Stores/Site/Location as per the Contractual Terms and Conditions.

2. Evaluation Criteria

- The bids will be evaluated technically on the compliance to tender terms and conditions.
- The bids will be evaluated commercially on the overall all-inclusive lowest cost for the complete tender BOQ / each line item as calculated in Schedule of Items. Tata Power however, reserves right to split the order line item wise and/or quantity wise among more than one Bidder. Hence all bidders are advised to quote their most competitive rates against each line item.

The Tata Power Company Ltd		OPEN TENDER NOTIFICATION
Tender Reference: CC24VJS050		Document Date: 1 st Jan 2024

- Bidder has to mandatorily quote against each item of Schedule of Items. Failing to do so, Tata Power may reject the bids.

NOTE: In case of a new bidder not registered with Tata Power, factory inspection and evaluation shall be carried out to ascertain bidder’s manufacturing capability and quality procedures. However Tata Power reserves the right to carry out factory inspection and evaluation for any bidder prior to technical qualification. In case a bidder is found as Disqualified in the factory evaluation, their bid shall not be evaluated any further and shall be summarily rejected. The decision of Tata Power shall be final and binding on the bidder in this regard.

2.1 Price Variation Clause and Cap: NA – On firm basis

3. Submission of Bid Documents

3.1 Bid Submission

Bidders are requested to submit their offer in line with this Tender document. Bids shall be submitted in 3 (three) parts:

FIRST PART: “EMD – BANK GUARANTEE” of Value detailed in 1.1 valid for 180 days from the due date of bid submission in the form of Bank Guarantee favoring ‘The Tata Power Company Limited’. The EMD has to be strictly in the format as mentioned in Tender Document, failing which it shall not be accepted by Tata Power and the bid as submitted shall be liable for rejection.

Note : BG of 180 days and further claim period of 180 days is needed. In case the same cannot be issued by your bank then BG valid for 365 days can be provided.

Tata Power Bank details for EMD BG / NEFT:

Beneficiary Name – The Tata Power Co. Ltd.

Bank Name – HDFC Bank Ltd.

Branch Name – Fort Branch, Mumbai

Address – Maneckji Wadia Building, Nanik Motwani Marg, Fort, Mumbai 400023.

Branch Code – 60

Bank & Branch Code – 400240015

Account No – 00600110000763

Account type – CC

IFSC Code – HDFC0000060

The hard copy of EMD in a sealed envelope should be sent on address mentioned in Tender document. Pls mail the UTR details in case of NEFT for verification.

First Part has to be submitted in Sealed Envelope.

SECOND PART: “TECHNICAL / UN-PRICED COMMERCIAL BID” shall contain the following documents:

- Documentary evidence in support of Technical, Commercial qualifying criteria

The Tata Power Company Ltd		OPEN TENDER NOTIFICATION
Tender Reference: CC24VJS050		Document Date: 1 st Jan 2024

- b) Technical literature/GTP/Type test report/Details of Qualified Manpower Available/ Testing Facility available etc. *(complete in all respect as desired and detailed in Technical Specification and Technical Requirement Section)*
- c) Duly filled Technical and Commercial Deviation Sheets
- d) Duly filled formats like Authorization affidavit form
- e) *Unpriced Commercial Bid*

The technical / un-priced commercial bid shall be properly indexed and is to be submitted in Soft Copy through E-Tender system of Tata Power. Hard Copy of Technical Bids need not be submitted.

Second Part has to be submitted through E-Tender System Only

THIRD PART: “PRICE BID” shall contain only the price details and strictly in Price Bid format along with explicit break up of basic prices and applicable GST. Basic price should include packaging forwarding, freight, transit insurance and any other cost envisaged by the bidder.

Third part has to be submitted through E-Tender System (ARIBA) only.

FOR BIDS INVITED THROUGH E-TENDER SYSTEM (TECHNICAL AND UN-PRICED COMMERCIAL BID) :

In response to advertisement Bidder has to provide details of person authorized to Bid on behalf of the Bidder. An e-mail will be generated by E-Tender System and the authorized person can download the Tender Documents from the system.

SECOND and THIRD PART of the Bid have to be submitted in E-Tender System.

Bidders have to mandatorily submit SECOND PART (Technical and Un-priced commercial Bid) only through E-Tender system of Tata Power. Bids submitted through any other form/ route shall not be admissible.

EMD BG to be sent in a sealed envelope which shall be clearly marked as below to the below address.

EMD

“Please mention Tender Reference No”

The Tata Power Company Limited, Smart Center of Procurement Excellence, 2nd Floor, Sahar Receiving Station, Near Hotel Leela, Sahar Airport Road, Andheri East, Mumbai-400059

Bids submitted by Email/Telex/Telegram /Fax will be rejected. No request from any Bidder to Tata Power to collect the proposals from Courier/Airlines/Cargo Agents etc. shall be entertained.

SIGNING OF BID DOCUMENTS:

The bid must contain the name, residence and place of business of the person or persons making the bid and must be signed and sealed by the Bidder with his usual signature. The names of all persons signing should also be typed or printed below the signature.

The Bid being submitted must be signed by a person holding a Power of Attorney authorizing him to do so, certified copies of which shall be enclosed.

The Bid submitted on behalf of companies registered with the Indian Companies Act, for the time being in force, shall be signed by persons duly authorized to submit the Bid on behalf of the Company and shall be accompanied by certified true copies of the resolutions, extracts of Articles of Association, special or general Power of Attorney etc. to show clearly the title, authority and designation of persons

The Tata Power Company Ltd		<i>OPEN TENDER NOTIFICATION</i>
<i>Tender Reference: CC24VJS050</i>		<i>Document Date: 1st Jan 2024</i>

signing the Bid on behalf of the Company. Satisfactory evidence of authority of the person signing on behalf of the Bidder shall be furnished with the bid.

A bid by a person who affixes to his signature the word ‘President’, ‘Managing Director’, ‘Secretary’, ‘Agent’ or other designation without disclosing his principal will be rejected.

The Bidder’s name stated on the Proposal shall be the exact legal name of the firm.

3.2 Contact Information

Communication Details: Detailed in 1.1

3.3 Bid Prices

Bidders shall quote for the entire Scope of Supply/ work with a break up of prices for individual items and Taxes & duties. The bidder shall complete the appropriate Price Schedules included herein, stating the Unit Price for each item & total price with taxes, duties & freight up to destination at various sites of Tata Power. The all-inclusive prices offered shall be inclusive of all costs as well as Duties, Taxes and Levies paid or payable during the execution of the supply work, breakup of price constituents.

The quantity break up shown else-where other than Price Schedule is tentative. The bidder shall ascertain himself regarding material required for completeness of the entire work. Any items not indicated in the price schedule but which are required to complete the job as per the Technical Specifications/ Scope of Work/ SLA mentioned in the tender, shall be deemed to be included in prices quoted.

3.4 Bid Currencies

Prices shall be quoted in Indian Rupees Only. It also may be noted that the denomination of Purchase Order / Outline Agreement / Rate Contract and associated Payment to Successful Bidder shall also be in Indian Rupees Only. In case Bidder intends to import any equipment, part etc and supply to Tata Power then all liability and costs related to import will rest with the Bidder. All statutory compliances, payments, expenditure etc related to importing of equipment will be responsibility of the bidder.

3.5 Period of Validity of Bids

Bids shall remain valid for 180 days from the due date of submission of the bid.

Notwithstanding clause above, Tata Power may solicit the Bidder’s consent to an extension of the Period of Bid Validity. The request and responses thereto shall be made in writing.

3.6 Alternative Bids

Bidders shall submit Bids, which comply with the Bidding documents. Alternative bids will not be considered. The attention of Bidders is drawn to the provisions regarding the rejection of Bids in the terms and conditions, which are not substantially responsive to the requirements of the bidding documents.

3.7 Modifications and Withdrawal of Bids

The bidder is not allowed to modify or withdraw its bid after the Bid’s submission. The EMD as submitted along with the bid shall be liable for forfeiture in such event.

The Tata Power Company Ltd		OPEN TENDER NOTIFICATION
Tender Reference: CC24VJS050		Document Date: 1 st Jan 2024

3.8 Earnest Money Deposit (EMD)

The bidder shall furnish, as part of its bid, an EMD amounting as specified in the tender. The EMD is required to protect the Tata Power against the risk of bidder's conduct which would warrant forfeiture. The EMD shall be in following form:

- Bank Guarantee valid for 180 days after due date of submission.

The EMD shall be forfeited in case of:

- a) The bidder withdraws its bid during the period of specified bid validity.

Or

- b) In case of a successful bidder, if the Bidder, within 15 days, does not
- i) accept the purchase order, or
 - ii) furnish the required Contract Performance Bank Guarantee (CPBG)

Original Bank Guarantee submitted as EMD shall be returned only after completion of award process for unsuccessful bidders and issue of Contract Performance Bank Guarantee (CPBG) for successful bidder.

4. Bid Opening & Evaluation process

4.1 Process to be confidential

Information relating to the examination, clarification, evaluation and comparison of Bids and recommendations for the award of a contract shall not be disclosed to Bidders or any other persons not officially concerned with such process. Any effort by a Bidder to influence Tata Powers processing of Bids or award decisions may result in the rejection of the Bidder's Bid.

4.2 Technical Bid Opening

Bids will be opened at Corporate Office of Tata Power as per our standard Process. The bids shall be opened internally by Tata Power. Technical bid must not contain any cost information whatsoever.

First the envelope marked "EMD" will be opened. Bids without EMD of required amount/ validity in prescribed format, shall be rejected.

Next, the technical bid of the bidders who have furnished the requisite EMD will be opened in E-Tender system.

4.3 Preliminary Examination of Bids/Responsiveness

Tata Power will examine the Bids to determine whether they are complete, whether any computational errors have been made, whether required sureties have been furnished, whether the documents have been properly signed, and whether the Bids are generally in order. Tata Power may ask for submission of original documents in order to verify the documents submitted in support of qualification criteria.

Prior to the detailed evaluation, Tata Power will determine the substantial responsiveness of each Bid to the Bidding Documents including production capability and acceptable quality of the Goods offered. A substantially responsive Bid is one, which conforms to all the terms and conditions of the Bidding Documents without material deviation.

Bid determined as not substantially responsive will be rejected by the Tata Power and/or the Tata Power and may not subsequently be made responsive by the Bidder by correction of the non-conformity.

The Tata Power Company Ltd		<i>OPEN TENDER NOTIFICATION</i>
<i>Tender Reference: CC24VJS050</i>		<i>Document Date: 1st Jan 2024</i>

4.4 Techno Commercial Clarifications

Bidders need to ensure that the bids submitted by them are complete in all respects. To assist in the examination, evaluation and comparison of Bids, Tata Power may, at its discretion, ask the Bidder for a clarification on its Bid for any deviations with respect to the Tata Power specifications and attempt will be made to bring all bids on a common footing. All responses to requests for clarification shall be in writing and no change in the price or substance of the Bid shall be sought, offered or permitted owing to any clarifications sought by Tata Power.

4.5 Price Bid Opening

The EMD of the bidder withdrawing or substantially altering his offer at any stage after the technical bid opening will be forfeited at the sole discretion of Tata Power without any further correspondence in this regard.

Arithmetical errors will be rectified on the following basis: If there is a discrepancy between the unit price and the total price per item that is obtained by multiplying the unit price and quantity, the unit price shall prevail and the total price per item will be corrected. If there is a discrepancy between the Total Amount and the sum of the total price per item, the sum of the total price per item shall prevail and the Total Amount will be corrected.

4.6 Reverse Auction and Price Matching Option

Tata Power reserves the right to go for Reverse Auction (RA) for price negotiation and discover the most competitive price on ARIBA portal, Tata Power's official e-tendering platform. This will be decided after techno-commercial evaluation of the bids. Bidders need to give their acceptance with the offer for participation in RA. Non-acceptance to participate in RA may result in non-consideration of their bids, in case Tata Power decides to go for RA.

Only those bidders who are techno-commercially qualified shall be eligible to participate further in RA process. However, the original H1 bidder (whose price bid is the highest post techno-commercial evaluation) shall not be allowed to participate in further RA process provided minimum three techno-commercially qualified bids are available.

For case where more than one bidders have to be awarded (including Rate Contract / Outline Agreement) Price Matching Option will be exercised. Volume of job allocated to original competitive bidder will be more than bidder who is chosen through Price Matching Option. Tata Power decision regarding work sharing shall be final and no explanation OR clarification shall be given regarding the same.

5.0 Award Decision

Tata Power will award the contract to the successful bidder whose bid has been determined to be the lowest-evaluated responsive bid as per the Evaluation Criterion mentioned at Clause 2.0. The Cost for the said calculation shall be taken as the all-inclusive cost quoted by bidder in Priced Bid Format subject to any corrections required in line with Clause 4.3 above. The decision to place purchase order/Outline Agreement/ Rate Contact solely depends on Tata Power on the cost competitiveness across multiple lots, quality, delivery and bidder's capacity, in addition to other factors that Tata Power may deem relevant.

The Tata Power Company Ltd	 TATA TATA POWER	<i>OPEN TENDER NOTIFICATION</i>
<i>Tender Reference: CC24VJS050</i>		<i>Document Date: 1st Jan 2024</i>

Tata Power reserves all the rights to award the contract to one or more bidders so as to meet the delivery requirement or nullify the award decision without assigning any reason thereof.

In case any supplier is found unsatisfactory during the delivery process, the award will be cancelled and Tata Power reserves the right to award other suppliers who are found fit.

5.1 Rate Contract / Outline Agreement

Rate Contract / Outline Agreement does not guarantee any assured business volume in Rupees or Quantity. Quantities are only indicative and specified for the purpose of readiness as per the request from Purchaser. Supplies shall be only against Firm Purchase Orders placed as per the agreed terms and conditions of Rate Contract / Outline Agreement. Purchaser shall be entitled at its discretion to place firm order for such supplies on "As and When Required Basis" without minimum take-off guarantee. Rate Contract / Outline Agreement will have list of Items with Unit Rate and applicable Taxes and Duties. There will be a cap on value for which order which can be placed against the Rate Contract / Outline Agreement. Actual quantity ordered for each line item may differ significantly from the tentative quantity indicated in the Tender Document. One / few / all items of Rate Contract / Outline Agreement can be ordered till the Cap Value is reached.

6.0 Order of Preference/Contradiction:

In case of contradiction in any part of various documents in tender, following shall prevail in order of preference:

1. Outline Agreement/Purchase Order (with Commercial conditions)
2. Special Terms and conditions (if applicable)
3. General Terms and conditions
4. Technical Specifications

In case there is a discrepancy in the BOQ mentioned in tender (to the extent modified through subsequent Corrigendum, if any) and the bid submitted by any bidder, the description as mentioned in the tender (to the extent modified through subsequent Corrigendum, if any) shall prevail.

7.0 Ethics

Tata Power is an ethical organization and as a policy Tata Power lays emphasis on ethical practices across its entire domain. Bidder should ensure that they should abide by all the ethical norms and in no form either directly or indirectly be involved in unethical practice.

Tata Power work practices are governed by the Tata Code of Conduct. Bidder is request to refer Tata Code of Conduct Clause in General Terms and Conditions.

8.0 General Condition of Contract and Special Condition of Contracts

Any condition not mentioned above shall be applicable as per General Terms and Conditions and Special Condition of Contracts attached along with this tender.

---XXX---

The Tata Power Company Ltd		<i>OPEN TENDER NOTIFICATION</i>
<i>Tender Reference: CC24VJS050</i>		<i>Document Date: 1st Jan 2024</i>

Annexure 1

Schedule Of Items

Sr. no.	Material / Service Short Text (as per SAP)	Quantity	UoM	Unit Rate (Basic)	Total
1	FEEDER, COMPACT FDR PLR 2 IC,630A&6 OG,CO	500	Mtrs.		-
2	PILLAR MINI 415V W/400A BUS BAR F/CABLE	80	Mtrs.		-
3	PANEL, MINI PILLAR WITH FUSES,	50	Mtrs.		-
	Sub Total				-
	GST @18%				-
	Total with taxes				-

The Tata Power Company Ltd		TECHNICAL SPECIFICATION OF 8 Way Compact Sub feeder Pillar Panels
ENSE-DS-2019-R00		Date of Issue: 22/12/2023

TECHNICAL SPECIFICATION

8 Way Compact Sub feeder Pillar Panels



*The Tata Power Company Ltd.
Engineering Services (ENSE),
Distribution Division,
Senapati Bapat Marg,
Lower Parel,
Mumbai – 400013
Maharashtra*



The Tata Power Company Ltd		TECHNICAL SPECIFICATION OF 8 Way Compact Sub feeder Pillar Panels
ENSE-DS-2019-R00		Date of Issue: 22/12/2023

TECHNICAL SPECIFICATION COVER SHEET

Document No: ENSE-DS-2019-R00

Document Title: Technical Specification of 8 Way Compact Sub feeder Pillar Panels



R00	ENSE-DS-2019-R00 For Tendering Purpose	22/12/2023	YMM		AVP		RMB	
Rev No.	Remarks	Date	Initials	Sign	Initials	Sign	Initials	Sign
			Prepared By		Reviewed By		Approved & Issued By	

Rev No.	Description	Prepared By & Date	Checked By & Date	Approved for Issue By & Date
R00	TECHNICAL SPECIFICATION OF 8 Way Compact Sub feeder Pillar Panels	Yash M. Mane 	Ajay V. Potdar 	Ravindra M. Bhanage 
		22/12/2023	22/12/2023	22/12/2023

The Tata Power Company Ltd		TECHNICAL SPECIFICATION OF 8 Way Compact Sub feeder Pillar Panels
ENSE-DS-2019-R00		Date of Issue: 22/12/2023

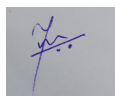

CONTENTS

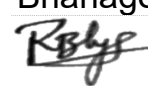
- 1.0 SCOPE
 - 2.0 APPLICABLE STANDARDS
 - 3.0 CLIMATIC CONDITIONS OF THE INSTALLATION
 - 4.0 GENERAL TECHNICAL REQUIREMENTS
 - 5.0 GENERAL CONSTRUCTIONS
 - 6.0 NAME PLATE & MARKINGS
 - 7.0 TESTS
 - 8.0 TYPE TEST CERIFICATES
 - 9.0 PRE-DISPATCH INSPECTION
 - 10.0 INSPECTION AFTER RECEIPT AT STORE
 - 11.0 GUARANTEE
 - 12.0 PACKING AND TRANSPORT
 - 13.0 TENDER SAMPLE
 - 14.0 QUALITY CONTROL
 - 15.0 MINIMUM TESTING FACILITIES
 - 16.0 MANUFACTURING ACTIVITIES
 - 17.0 SPARES, ACCESSORIES AND TOOLS
 - 18.0 DRAWING AND DOCUMENTS
 - 19.0 SCHEDULE "A" GUARANTEED TECHNICAL PARTICULARS
 - 20.0 SCHEDULE "B" DEVIATIONS
- + ANNEXURE 1 & 2

Rev No.	Description	Prepared By & Date	Checked By & Date	Approved for Issue By & Date
R00	TECHNICAL SPECIFICATION OF 8 Way Compact Sub feeder Pillar Panels	Yash M. Mane 	Ajay V. Potdar 	Ravindra M. Bhanage 
		22/12/2023	22/12/2023	22/12/2023

The Tata Power Company Ltd		TECHNICAL SPECIFICATION OF 8 Way Compact Sub feeder Pillar Panels
ENSE-DS-2019-R00		Date of Issue: 22/12/2023

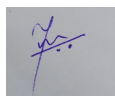
1.0	SCOPE	<p>This specification covers design, engineering, manufacture; shop testing, inspection, painting, packing, and supply of 415V Sub Feeder Pillar complete with all accessories for efficient and trouble-free operation of the distribution network for Tata Power Company Limited at Mumbai.</p> <p>It is not our intent to specify completely herein all details of design and construction of the equipment. However, the equipment shall conform in all respects to high standards of Engineering design and workmanship and shall be capable of performing in a manner acceptable to the purchaser (TPC) who will interpret the meaning of drawings and specification and shall be entitled to reject any work or material which in his judgement is not in full accordance therewith.</p> <p>All the bought-out items shall be of reputed make and shall be subject to approval by the PURCHASER (TPC) after award of contract. All SUBVENDOR/SUBCONTRACTOR list shall also be subject to approval by the PURCHASER (TPC) after award of contract.</p>																						
2.0	APPLICABLE STANDARDS	<p>The equipment (and the materials used) covered by this specification shall unless otherwise stated, be designed, manufactured and tested in accordance with the latest editions of the following Indian, IEC / International standards, with latest amendment from time to time, thereof, some of which are listed below:</p> <p>The Sub Feeder Pillar shall comply with the requirements stated in the latest editions of the following recommendations, standard and specifications:</p> <table border="1" style="width: 100%; border-collapse: collapse;"> <thead> <tr> <th style="text-align: center;">INDIAN STANDARDS (IS)</th> <th style="text-align: center;">Title</th> </tr> </thead> <tbody> <tr> <td>IS 5039</td> <td>Specification for distribution pillars below 1000V AC</td> </tr> <tr> <td>IS 5</td> <td>Colour of ready mixed paints and enamels</td> </tr> <tr> <td>IS 191</td> <td>Copper Specification</td> </tr> <tr> <td>IS 13703-2</td> <td>Low voltage fuses for voltage not exceeding 1000 V AC or 1500 V DC. Part 2 - Fuses for use by authorized persons</td> </tr> <tr> <td>IS 5082</td> <td>Wrought aluminium and aluminium alloy bars, rods, tubes, sections, plates and sheets for electrical applications</td> </tr> <tr> <td>IS 1359</td> <td>Electroplated Coatings of Tin</td> </tr> <tr> <td>IS 1730</td> <td>Dimensions for steel plates, sheets strips and flats for general engineering purposes</td> </tr> <tr> <td>IS 2551</td> <td>Danger Notice plates</td> </tr> <tr> <td>IS 4759</td> <td>Hot-dip Zinc coatings on structural steel and other allied products</td> </tr> <tr> <td>IS 14772</td> <td>General requirements for enclosures for accessories for household and similar fixed electrical installations</td> </tr> </tbody> </table>	INDIAN STANDARDS (IS)	Title	IS 5039	Specification for distribution pillars below 1000V AC	IS 5	Colour of ready mixed paints and enamels	IS 191	Copper Specification	IS 13703-2	Low voltage fuses for voltage not exceeding 1000 V AC or 1500 V DC. Part 2 - Fuses for use by authorized persons	IS 5082	Wrought aluminium and aluminium alloy bars, rods, tubes, sections, plates and sheets for electrical applications	IS 1359	Electroplated Coatings of Tin	IS 1730	Dimensions for steel plates, sheets strips and flats for general engineering purposes	IS 2551	Danger Notice plates	IS 4759	Hot-dip Zinc coatings on structural steel and other allied products	IS 14772	General requirements for enclosures for accessories for household and similar fixed electrical installations
INDIAN STANDARDS (IS)	Title																							
IS 5039	Specification for distribution pillars below 1000V AC																							
IS 5	Colour of ready mixed paints and enamels																							
IS 191	Copper Specification																							
IS 13703-2	Low voltage fuses for voltage not exceeding 1000 V AC or 1500 V DC. Part 2 - Fuses for use by authorized persons																							
IS 5082	Wrought aluminium and aluminium alloy bars, rods, tubes, sections, plates and sheets for electrical applications																							
IS 1359	Electroplated Coatings of Tin																							
IS 1730	Dimensions for steel plates, sheets strips and flats for general engineering purposes																							
IS 2551	Danger Notice plates																							
IS 4759	Hot-dip Zinc coatings on structural steel and other allied products																							
IS 14772	General requirements for enclosures for accessories for household and similar fixed electrical installations																							

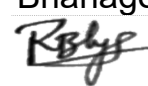
Rev No.	Description	Prepared By & Date	Checked By & Date	Approved for Issue By & Date
R00	TECHNICAL SPECIFICATION OF 8 Way Compact Sub feeder Pillar Panels	Yash M. Mane 	Ajay V. Potdar 	Ravindra M. Bhanage 
		22/12/2023	22/12/2023	22/12/2023

IEC STANDARDS	Title
IEC TR 61439-0	Low-voltage switchgear and controlgear assemblies-Part 0: Guidance to specifying assemblies
IEC 60947-3	Low-voltage switchgear and controlgear - Part 3: Switches, disconnectors, switch-disconnectors and fuse-combination units.
IEC 60947-1	Low-voltage switchgear and controlgear - Part 1: General rules
IEC 61439-2	Low-voltage switchgear and controlgear assemblies - Part 2: Power switchgear and controlgear assemblies
IEC 60664	Insulation coordination for equipment within low-voltage systems - ALL PARTS
IEC 60269-1	Low-Voltage Fuses Part 1 General Requirements
IEC 61439-2	Low-voltage switchgear and controlgear assemblies Part 2: Power switchgear and controlgear assemblies
IEC 60529	Degrees of protection provided by enclosures (IP Code)



In case of any conflict on any technical particular in the specification, the stricter requirement mentioned in the relevant standard shall be valid.

3.0

**CLIMATIC
CONDITIONS
OF THE
INSTALLATION**

1	Maximum ambient temperature	43 deg.C
2	Max. Daily average ambient temp	35 deg.C
3	Min Ambient Temperature	07 deg.C
4	Maximum Relative Humidity	100%
5	Minimum Relative Humidity	40%
6	Average No. of thunderstorm per annum	50
7	Average Annual Rainfall	2380mm
8	Average No. of rainy days per annum	115
9	Rainy months	June to Oct.
10	Altitude above MSL not exceeding	300 meters
11	Average Air Pressure	29.6-inch Hg



Atmosphere is generally laden with mild acid and dust suspended during summer months and subjected to fog in winter months. The design of the equipment and accessories shall be suitable to withstand seismic forces corresponding to an acceleration of 0.1g.

Rev No.	Description	Prepared By & Date	Checked By & Date	Approved for Issue By & Date
R00	TECHNICAL SPECIFICATION OF 8 Way Compact Sub feeder Pillar Panels	Yash M. Mane 	Ajay V. Potdar 	Ravindra M. Bhanage 
		22/12/2023	22/12/2023	22/12/2023

4.0



GENERAL TECHNICAL REQUIREMENTS

Sr. No.	Item Description	Tata Power Requirement
1	Manufacturer	Name
		Manufacturer Address
		Contact telephone no
2	Basic design	A totally enclosed free standing floor mounted self-supporting metal sheet cubical containing bus-bars connected to distribution feeders protected Complied through HRC type fuse base.
3	Main bus bar rating	As per Specification
4	No of incoming feeders	Quantity- 2 nos
		Incomer Rating
4a	No of outgoing feeders (Type 8 way)	Quantity- 6 nos
		Outgoing Rating
5	Panel construction	CRCA sheet steel
6	Panel enclosure class	IP54 - ingress protection (for outdoor installation)
7	Sheet thickness	As per Specification
8	Door type for front access	Double door for feeder pillar
9	Door hinges	Minimum three anti-theft type hinges self-locking type.
10	Padlocking facility	As per Specification
11	Master key for all doors	Identical for all panels,
		1 no./ panel
12	External steel hardware	Galvanized nut & bolts 8.8 Grade
13	Phase & neutral Bus bar	Aluminium grade 19501 (H2)
		as per IS 5082
14	Current Density of Aluminum busbars	1 A/sq mm
15	Bus bar colour coding for R, Y, B & neutral	Heat shrinkable sleeves with colour Red, Yellow, Blue & Black respectively
16	Bus bar size in mm for 630 A I/C	80x10mm for Phase & Neutral (Minimum)
17	Bus bar size in mm for 315A O/G	1x40x10mm for Phase (Minimum)
18	Earth bus size	50x10 mm GI
19	Main bus bar short circuit withstand capacity	Above 50kA for 1 sec as per IEC 61439
20	Permissible maximum temperature rise above ambient of 40°C	Busbar: 45 deg C Terminals: 65 deg C
21	Bus bar support insulators	As per IS13410 SMC / DMC, 1100V grade

Rev No.	Description	Prepared By & Date	Checked By & Date	Approved for Issue By & Date
R00	TECHNICAL SPECIFICATION OF 8 Way Compact Sub feeder Pillar Panels	Yash M. Mane 	Ajay V. Potdar 	Ravindra M. Bhanage 
		22/12/2023	22/12/2023	22/12/2023

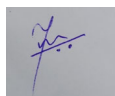

The Tata Power Company Ltd		TECHNICAL SPECIFICATION OF 8 Way Compact Sub feeder Pillar Panels
ENSE-DS-2019-R00		Date of Issue: 22/12/2023

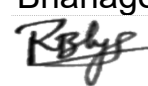
		22	Number of Bus Bar Supports	2 nos per phase & neutral
		23	Incoming Cable	2 Runs x 4C 300 Sq.mm
		24	Outgoing Cable	1 Run X 4C 300 Sq.mm
		25	Fuse Base	6 no. 400A, Per phase & 2 no. 630A, Per phase
		25a	Make (Fuse Base & Fuse Links)	Schneider/ L&T/ Siemens/ GE Power Controls/ HPL/ Havells/ Jean Muller / Bussman.
		25b	Fuses (630A, 315A)	HRC plug-in type
		26	Gland plate at panel bottom	Cold rolled close annealed (CRCA) sheet steel 3 mm thick. It shall be possible to temporarily detach the base plate for installation and connection of cables. SS nuts and bolts. Grommet: Fire retardant EPDM rubber grommet shall be provided on holes for cable entry.
		27	Cable termination clearance	300mm minimum from gland plate
		28	Earth studs on both side of panel bottom	With M10 galvanized steel nut bolts
		29	Panel maximum dimensions in mm	Width X Depth X Height
		-		950 mm X 400 mm X 1766 mm (or less)
		30	Clearance between live parts	Phase - phase: 25 mm (minimum)
				Phase - earth: 20 mm (minimum)
		31	Continuous rated operating voltage	415 volt +/- 10%
		32	High voltage withstand capacity	2000 volt at 50 Hz for 1minute
		33	Insulation resistance ph-ph & ph-earth	Minimum 100MOhm with 500V Megger.
		34	Surface preparation for painting	Sand blasting or 7 tank process
		35	Painting	Power coated grade A PU paint min thickness 120 micron
		36	Shade	International Orange shade No 592 of IS-5
		37	Fluorescent strip	2 Nos. retro reflective sticker 3M (should reflect vehicular lights during night) strips of Yellow colour each of 75 mm width shall be provided on all sides.
38	Panel drawing	To be submitted with GTP		
39	Bulb	LED		
40	Type Test certificate	Type Test to be conducted on one unit of this design.		
5.0	GENERAL			

Rev No.	Description	Prepared By & Date	Checked By & Date	Approved for Issue By & Date
R00	TECHNICAL SPECIFICATION OF 8 Way Compact Sub feeder Pillar Panels	Yash M. Mane 	Ajay V. Potdar 	Ravindra M. Bhanage 
		22/12/2023	22/12/2023	22/12/2023



The Tata Power Company Ltd		TECHNICAL SPECIFICATION OF 8 Way Compact Sub feeder Pillar Panels
ENSE-DS-2019-R00		Date of Issue: 22/12/2023

	CONSTRUCTION	Compact Sub feeder Pillar - TPN Bus bar with 2 fuses (for incomer) & 6 fuses (for outgoing).																																															
		<table border="1"> <thead> <tr> <th>Sr. No.</th> <th>Parameter</th> <th>Requirement</th> </tr> </thead> <tbody> <tr> <td>1</td> <td>Basic Design</td> <td>A totally enclosed free standing floor mounted self-supporting metal sheet cubical containing bus-bars connected to distribution feeders.</td> </tr> <tr> <td>2</td> <td>Number of Ways</td> <td>The maximum number of circuits for which the shall be designed: Sub feeder Pillar with Fuses: 8 Way</td> </tr> <tr> <td>3</td> <td>Neutral bus</td> <td>At bottom of panel, with M10 Nut- Bolts for terminating incoming & outgoing Pillar cable neutral circuit</td> </tr> <tr> <td>4</td> <td>Earth Bus</td> <td>Earth strip of 50X10mm GI</td> </tr> </tbody> </table> <p>A. Enclosure:</p> <table border="1"> <thead> <tr> <th>Sr. No.</th> <th>Parameter</th> <th>Requirement</th> </tr> </thead> <tbody> <tr> <td>1</td> <td>Application</td> <td>Outdoor type</td> </tr> <tr> <td>2</td> <td>Material</td> <td>Cold Rolled Close Annealed (CRCA) sheet steel - powder coated.</td> </tr> <tr> <td>3</td> <td>Thickness of enclosure</td> <td>3 mm. Able to withstand rough weather conditions.</td> </tr> <tr> <td>4</td> <td>Finishing of enclosure</td> <td>Pre-treated & powder coating minimum 120 microns at any point of measurement</td> </tr> <tr> <td>5</td> <td>Design</td> <td>Compact and enclosure shall be designed to facilitate easy maintenance at a minimum height of 270 mm above FFL</td> </tr> <tr> <td rowspan="3">6</td> <td rowspan="3">Design at top</td> <td>Sloping canopy at top so that rain water does not accumulate.</td> </tr> <tr> <td>Minimum 10 degree slanting slope and extended 50 mm outside</td> </tr> <tr> <td>Lifting lug- 2 nos. lug welded on top. Eyebolt of suitable sizes shall be provided for lifting arrangements.</td> </tr> <tr> <td>7</td> <td>Degree of Protection</td> <td>IP54 suitable for outdoor installation</td> </tr> <tr> <td rowspan="3">8</td> <td rowspan="3">Gland plate at panel bottom</td> <td>Mild Steel 3 mm thick</td> </tr> <tr> <td>Removable detachable base plate per cable circuit. It shall be possible to temporarily detach the base plate for installation and connection of cables.</td> </tr> <tr> <td>SS nuts and bolts.</td> </tr> <tr> <td>9</td> <td>Fluorescent strip / painting on panel</td> <td>2 Nos. retro reflective sticker 3M or paint (should reflect vehicular lights during night) strips of yellow colour each of 75 mm width shall be provided on all sides. Paint shall have good colour retention, UV and</td> </tr> </tbody> </table>	Sr. No.	Parameter	Requirement	1	Basic Design	A totally enclosed free standing floor mounted self-supporting metal sheet cubical containing bus-bars connected to distribution feeders.	2	Number of Ways	The maximum number of circuits for which the shall be designed: Sub feeder Pillar with Fuses: 8 Way	3	Neutral bus	At bottom of panel, with M10 Nut- Bolts for terminating incoming & outgoing Pillar cable neutral circuit	4	Earth Bus	Earth strip of 50X10mm GI	Sr. No.	Parameter	Requirement	1	Application	Outdoor type	2	Material	Cold Rolled Close Annealed (CRCA) sheet steel - powder coated.	3	Thickness of enclosure	3 mm. Able to withstand rough weather conditions.	4	Finishing of enclosure	Pre-treated & powder coating minimum 120 microns at any point of measurement	5	Design	Compact and enclosure shall be designed to facilitate easy maintenance at a minimum height of 270 mm above FFL	6	Design at top	Sloping canopy at top so that rain water does not accumulate.	Minimum 10 degree slanting slope and extended 50 mm outside	Lifting lug- 2 nos. lug welded on top. Eyebolt of suitable sizes shall be provided for lifting arrangements.	7	Degree of Protection	IP54 suitable for outdoor installation	8	Gland plate at panel bottom	Mild Steel 3 mm thick	Removable detachable base plate per cable circuit. It shall be possible to temporarily detach the base plate for installation and connection of cables.	SS nuts and bolts.	9
Sr. No.	Parameter	Requirement																																															
1	Basic Design	A totally enclosed free standing floor mounted self-supporting metal sheet cubical containing bus-bars connected to distribution feeders.																																															
2	Number of Ways	The maximum number of circuits for which the shall be designed: Sub feeder Pillar with Fuses: 8 Way																																															
3	Neutral bus	At bottom of panel, with M10 Nut- Bolts for terminating incoming & outgoing Pillar cable neutral circuit																																															
4	Earth Bus	Earth strip of 50X10mm GI																																															
Sr. No.	Parameter	Requirement																																															
1	Application	Outdoor type																																															
2	Material	Cold Rolled Close Annealed (CRCA) sheet steel - powder coated.																																															
3	Thickness of enclosure	3 mm. Able to withstand rough weather conditions.																																															
4	Finishing of enclosure	Pre-treated & powder coating minimum 120 microns at any point of measurement																																															
5	Design	Compact and enclosure shall be designed to facilitate easy maintenance at a minimum height of 270 mm above FFL																																															
6	Design at top	Sloping canopy at top so that rain water does not accumulate.																																															
		Minimum 10 degree slanting slope and extended 50 mm outside																																															
		Lifting lug- 2 nos. lug welded on top. Eyebolt of suitable sizes shall be provided for lifting arrangements.																																															
7	Degree of Protection	IP54 suitable for outdoor installation																																															
8	Gland plate at panel bottom	Mild Steel 3 mm thick																																															
		Removable detachable base plate per cable circuit. It shall be possible to temporarily detach the base plate for installation and connection of cables.																																															
		SS nuts and bolts.																																															
9	Fluorescent strip / painting on panel	2 Nos. retro reflective sticker 3M or paint (should reflect vehicular lights during night) strips of yellow colour each of 75 mm width shall be provided on all sides. Paint shall have good colour retention, UV and																																															



Rev No.	Description	Prepared By & Date	Checked By & Date	Approved for Issue By & Date
R00	TECHNICAL SPECIFICATION OF 8 Way Compact Sub feeder Pillar Panels	Yash M. Mane  22/12/2023	Ajay V. Potdar  22/12/2023	Ravindra M. Bhanage  22/12/2023

The Tata Power Company Ltd		TECHNICAL SPECIFICATION OF 8 Way Compact Sub feeder Pillar Panels
ENSE-DS-2019-R00		Date of Issue: 22/12/2023

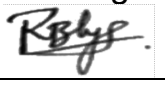
				weather resistant									
				"STICK NO BILLS" to be painted on both sides of the Compact Sub Feeder Pillar with Black Colour on Yellow Background.									
				10	Dimensions (max)	<table border="1"> <tr> <th>Width</th> <th>Depth</th> <th>Height</th> </tr> <tr> <td>950</td> <td>400</td> <td>1766</td> </tr> </table>	Width	Depth	Height	950	400	1766	
				Width	Depth	Height							
				950	400	1766							
				11	Stand	Legs - Iron angle of 40 x 40 x 5 mm at each corner and also hot dipped galvanized							
						Height of leg 250 mm							
						Welded plate at bottom of each leg should have hole of at least 21 mm for fixing of foundation bolt.							
						Bottom holes on four sides- Oval shape, for grouting bolts							
				12	Louvers	The panel shall be of dust and vermin proof construction and of self-cooled design with adequate louvers on side's portion. The louvers shall have fine wire mesh. Vermin Proof should be done with gaskets. (Minimum 2 Nos on each sides)							
				13	Paint shade	International Orange shade No 592 of IS-5 with minimum 120 microns thickness. Good retention and UV & weather resistant paint.							
				14	Surface preparation for painting	Sand blasting or 7 tank process followed by powder coating							
				15	Foundation Bolts	Required Number of Foundation Bolts to be supplied with the panel.							
				16	External hardware	Galvanized steel nut & bolts, Yellow zinc plated with grade 8.8 for Electrical contacts. Other hardware of grade 4.6							
				17	Clearance	Minimum Phase to phase clearance of 25mm and Phase to Neutral / Earth clearance of 20mm shall be provided in the panel.							
				18	Bolted Covers	Panel Should have internally bolted, removable back cover with handles.							
				19	Insulation sheets	All enclosure shall be covered with bolted min 1.5 mm thick SMC/FRP sheets from inside.							
				B. Doors:									
				<table border="1"> <thead> <tr> <th>Sr. No.</th> <th>Parameter</th> <th>Requirement</th> </tr> </thead> <tbody> <tr> <td>1</td> <td>Material of door</td> <td>Cold Rolled Close Annealed (CRCA) sheet steel - powder coated.</td> </tr> </tbody> </table>				Sr. No.	Parameter	Requirement	1	Material of door	Cold Rolled Close Annealed (CRCA) sheet steel - powder coated.
				Sr. No.	Parameter	Requirement							
1	Material of door	Cold Rolled Close Annealed (CRCA) sheet steel - powder coated.											

Rev No.	Description	Prepared By & Date	Checked By & Date	Approved for Issue By & Date
R00	TECHNICAL SPECIFICATION OF 8 Way Compact Sub feeder Pillar Panels	Yash M. Mane 	Ajay V. Potdar 	Ravindra M. Bhanage 
		22/12/2023	22/12/2023	22/12/2023

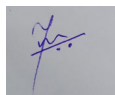
The Tata Power Company Ltd				TECHNICAL SPECIFICATION OF 8 Way Compact Sub feeder Pillar Panels										
ENSE-DS-2019-R00				Date of Issue: 22/12/2023										
		2	Thickness	Thickness - 2.5 mm										
		3	Type of Door arrangement	<p>The door shall be so fitted as to provide the interior with maximum protection from atmospheric conditions.</p> <p>For Compact Sub Feeder Pillar center opening double door on front.</p>										
		4	Insulation	All doors shall be covered with min 1.5 mm thick SMC/FRP sheets.										
		5	Hinges	Minimum 3 Nos. anti-theft hinges for each door. Hinges shall not be visible from outside and should not be removable.										
				Material of hinges and screws: Heavy duty stainless steel (SS)										
				Hinges shall be of such construction that the doors can be swung open by not less than 120 deg.										
		6	Engraving	SLD shall be engraved & pasted on inside part of door										
		7	Gasket	The panel shall be provided with gasket all round the perimeter of covers, gland plates, removable covers and doors										
		8	Door handles	On front										
		9	Paint shade	<p>International Orange shade No 592 of IS-5 with minimum 120 microns thickness. Good retention and UV & weather resistant paint.</p> <p>2 Nos. retro reflective sticker 3M or paint (should reflect vehicular lights during night) strips of yellow colour each of 75 mm width shall be provided on all sides.</p>										
10	Surface preparation for painting	Sand blasting or 7 tank process followed by powder coating												
C. Lock:														
<table border="1"> <thead> <tr> <th>Sr. No.</th> <th>Parameter</th> <th>Requirement</th> </tr> </thead> <tbody> <tr> <td>1</td> <td>Arrangement</td> <td>3 types of lock arrangement: a) Padlock b) Sliding Bolt latch c) Door latch on inner side of door: Tower bolts shall be provided at top and bottom</td> </tr> <tr> <td>2</td> <td>Material of locking mechanism</td> <td>a) For Padlock: Same as that of enclosure b) Sliding Bolt latch of Aluminium c) For Door latch on inner side of door - Stainless Steel</td> </tr> </tbody> </table>						Sr. No.	Parameter	Requirement	1	Arrangement	3 types of lock arrangement: a) Padlock b) Sliding Bolt latch c) Door latch on inner side of door: Tower bolts shall be provided at top and bottom	2	Material of locking mechanism	a) For Padlock: Same as that of enclosure b) Sliding Bolt latch of Aluminium c) For Door latch on inner side of door - Stainless Steel
Sr. No.	Parameter	Requirement												
1	Arrangement	3 types of lock arrangement: a) Padlock b) Sliding Bolt latch c) Door latch on inner side of door: Tower bolts shall be provided at top and bottom												
2	Material of locking mechanism	a) For Padlock: Same as that of enclosure b) Sliding Bolt latch of Aluminium c) For Door latch on inner side of door - Stainless Steel												
D. Apron:														
<table border="1"> <thead> <tr> <th>Sr. No.</th> <th>Parameter</th> <th>Requirement</th> </tr> </thead> <tbody> <tr> <td>1</td> <td>Material</td> <td>Cold rolled close annealed (CRCA) sheet steel</td> </tr> <tr> <td colspan="2"></td> <td>Apron shall be provide below the door level</td> </tr> </tbody> </table>						Sr. No.	Parameter	Requirement	1	Material	Cold rolled close annealed (CRCA) sheet steel			Apron shall be provide below the door level
Sr. No.	Parameter	Requirement												
1	Material	Cold rolled close annealed (CRCA) sheet steel												
		Apron shall be provide below the door level												

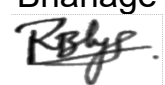
Rev No.	Description	Prepared By & Date	Checked By & Date	Approved for Issue By & Date
R00	TECHNICAL SPECIFICATION OF 8 Way Compact Sub feeder Pillar Panels	Yash M. Mane 	Ajay V. Potdar 	Ravindra M. Bhanage 
		22/12/2023	22/12/2023	22/12/2023

The Tata Power Company Ltd		TECHNICAL SPECIFICATION OF 8 Way Compact Sub feeder Pillar Panels
ENSE-DS-2019-R00		Date of Issue: 22/12/2023

2	Design	of Mini Pillar up to length of 270 mm on all 4 sides and easily removable such that exposed cables are not visible.
3	Thickness	3 mm minimum
4	Colour	Black

E. Cable Connection:

Sr. No.	Parameter	Requirement
1	Cable entry direction	Cable entry shall be from bottom of Compact Sub Feeder Pillar.
2	Cable termination clearance from gland plate.	300 mm minimum
3	Cable termination	All cable terminations shall be from the front side of the Compact Sub Feeder Pillar only



F. Bus- bars:

Busbars shall be of electrolytic grade aluminium with Bakelite shrouding, rated for 800 A, 50 kA for 1 sec and shall have adequate cross section to carry the continuous rated current and short time current. Main Busbar should be continuous/ without any joint. All bus bars, bus taps and joints shall be insulated. Neutral bus bar shall be provided on rear side & rated for full bus bar rating.

Sr. No.	Parameter	Requirement	
1	Material grade	Phase & Neutral bus-bars as per IS 5082 - Aluminium grade 19501 (H2).	
2	Bus-bar colour coding for R, Y, B & Neutral	Heat shrinkable insulation sleeves (1.1 kV voltage grade and min. Class A insulation class) of colour Red, Yellow, Blue and Black respectively.	
3	Bus-bar size (in mm)	2x40x10mm for Phase & Neutral (Al)	
4	Bus-bar configuration	Single bus-bars (per phase and neutral) shall be provided.	
5	Bus-bar arrangement	Horizontally placed, with R phase bus at top.	
6	Bus-bar phase barriers/ Phase separators (R-Y & Y-B)	FRP insulating sheet - (to be placed near to the phase bus-bar) (min 3 mm thickness) shall be provided between bus-bars, so as to ensure that there is no accidental contact with any live parts. (65 mm width)	
7	Bus-bar support insulators	2 nos per phase and neutral	
8	Cable size	Incoming	Outgoing
		2 Runs of 4C x 300 sq.mm.	1 Run of 4C x 300 sq.mm.

G. Panel Configuration:

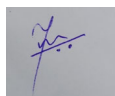
Sr. No.	Parameter	Requirement
1	No. of Incoming	2

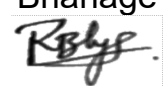
Rev No.	Description	Prepared By & Date	Checked By & Date	Approved for Issue By & Date
R00	TECHNICAL SPECIFICATION OF 8 Way Compact Sub feeder Pillar Panels	Yash M. Mane  22/12/2023	Ajay V. Potdar  22/12/2023	Ravindra M. Bhanage  22/12/2023

The Tata Power Company Ltd		TECHNICAL SPECIFICATION OF 8 Way Compact Sub feeder Pillar Panels
ENSE-DS-2019-R00		Date of Issue: 22/12/2023

2	No. of outgoing	6
---	-----------------	---



H. Earthing:

Sr. No.	Parameter	Requirement
1	Earth studs	On both sides of panel bottom. Shall be provide with M10 galvanized steel nut bolts washers. The earthing studs shall be welded from inside the enclosure.
2	Earth bus-bar	To be provided at panel bottom. 50 x 10 mm GI. The earth bus-bar shall be internally connected to two separate earth terminals located outside (on both sides of enclosure). The earth bus-bar shall be located at sufficient height from the gland plate.
3	Flexible earth connection to doors	Flexible PVC Copper wire 1.5 sq.mm. with green colour insulation on all doors.
4	Body Earthing	All hinged doors, Covers, Gland Plates shall be connected to the earth terminal, with the help of green coloured braided copper conductors of adequate size
5	Neutral Earth link	Earth Bus and Neutral Bus to be shorted with 50 x 10 mm GI link.

I. Fuse and Fuse base:

Sr. No.	Parameter	Requirement
1	Type of HRC fuse	Knife type DIN HRC fuse with fuse links as per IEC 60269-1, with tinned copper contacts.
2	Fuse puller	It shall be possible to replace the fuses on live system without compromising on safety.
3	Fuse base current carrying part	Tin plated copper (with spring) as IS 191
4	Fuse base material	DMC
5	Fuse fixing with bus-bars	Bolted type connection
6	Fuse links	Incoming: 630 A Type 3 Outgoing: 315 A Type 2
7	Fuse Base	Fuse base shall have adequate contact surface with the busbars provided to ensure that no local heating takes place. Incoming 2 nos, 630A Outgoing 6 Nos, 400 A
8	Fuse Outlet Clearances	Clearance of minimum 100mm between each fuse outlet and 125mm between fuse outlet and body of panel to be maintained.

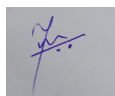
J. Lighting Provision:

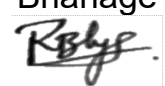
Rev No.	Description	Prepared By & Date	Checked By & Date	Approved for Issue By & Date
R00	TECHNICAL SPECIFICATION OF 8 Way Compact Sub feeder Pillar Panels	Yash M. Mane 	Ajay V. Potdar 	Ravindra M. Bhanage 
		22/12/2023	22/12/2023	22/12/2023

Sr. No.	Parameter	Requirement
1	Light bulb with holder	240 V LED bulb along with lamp holder, controlled through 2 Amp SP MCB.
2	Power Socket	240 V Single Phase 5/15 Amp five pin socket controlled through 15 Amp SP MCB

K. Danger Board / Branding:

Sr. No.	Parameter	Requirement
1	Danger Board	Danger boards shall be provided in local language also on the on front & rear cover with red background and with white letters.
2	Danger Marking	Front and rear side danger making with skull and bones with mention of voltage level of 440V AC as per IS 2551.
3	Branding Plate	Separate metallic name plate with Tata Power Logo of Dimension 12*12 Inches as per Annexure 1

Reference GA DRAWING:

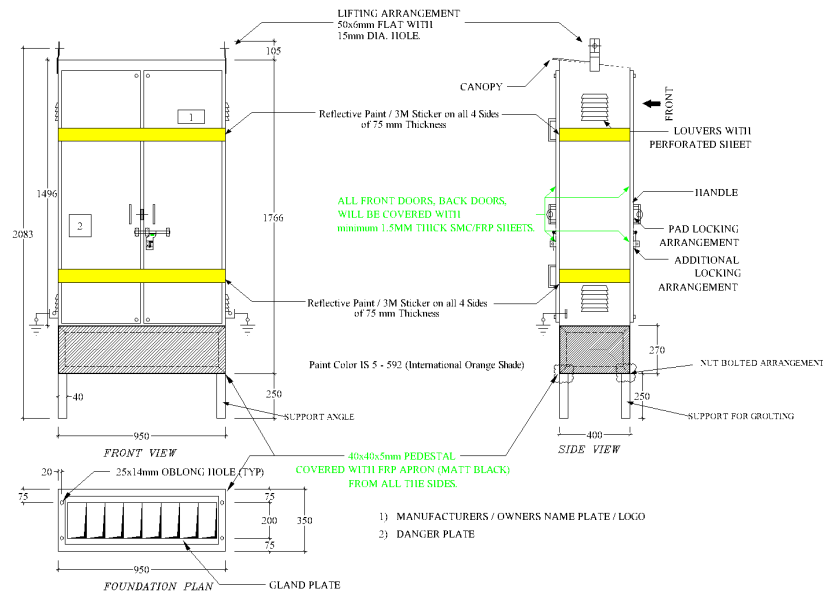

Rev No.	Description	Prepared By & Date	Checked By & Date	Approved for Issue By & Date
R00	TECHNICAL SPECIFICATION OF 8 Way Compact Sub feeder Pillar Panels	Yash M. Mane 	Ajay V. Potdar 	Ravindra M. Bhanage
		22/12/2023	22/12/2023	22/12/2023

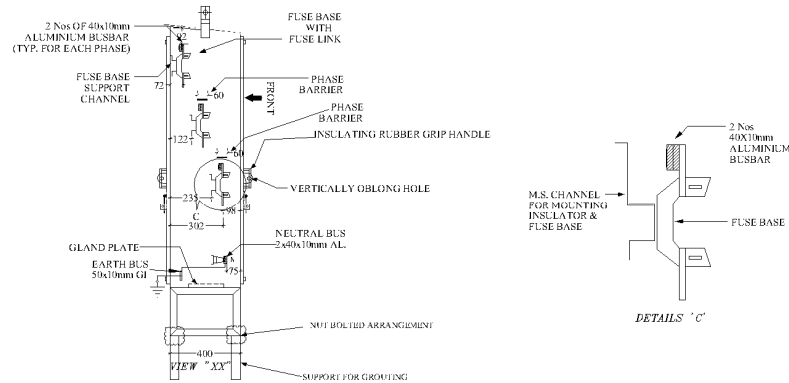
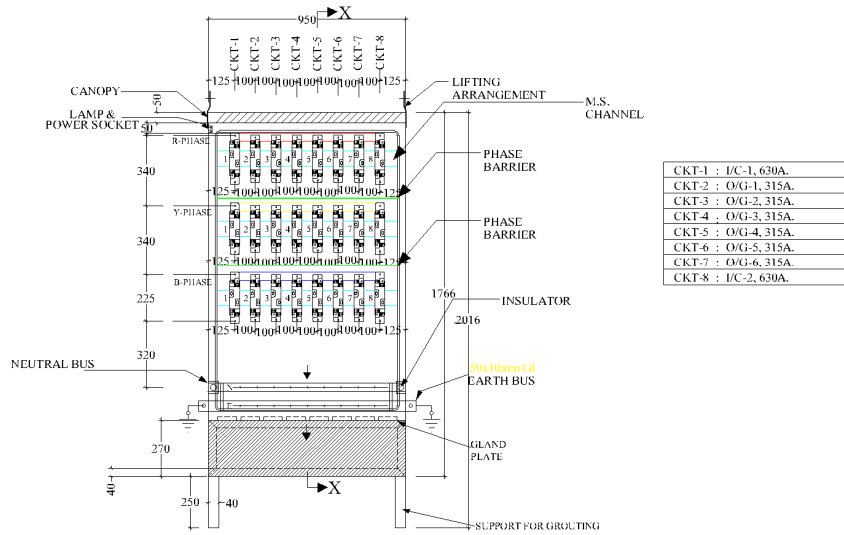

Rev No.	Description	Prepared By & Date	Checked By & Date	Approved for Issue By & Date
R00	TECHNICAL SPECIFICATION OF 8 Way Compact Sub feeder Pillar Panels	Yash M. Mane 	Ajay V. Potdar 	Ravindra M. Bhanage
		22/12/2023	22/12/2023	22/12/2023

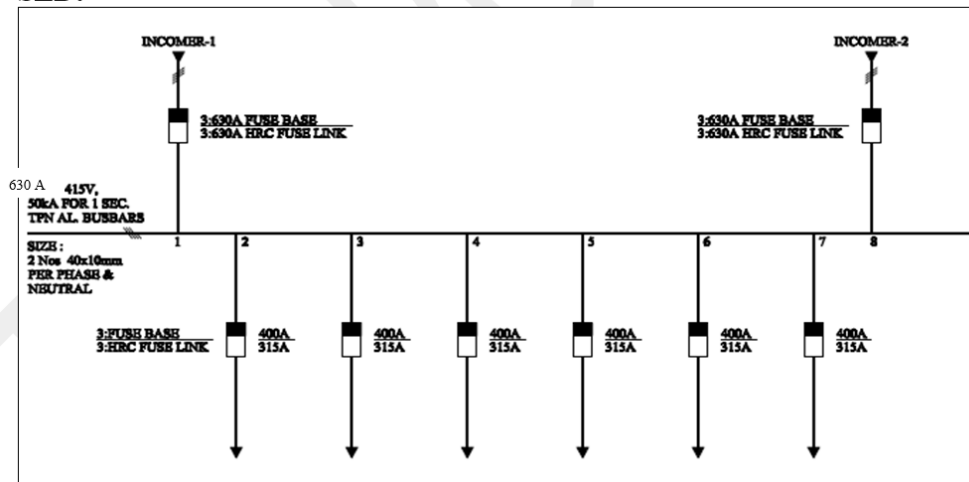
SLD:

6.0

**NAME PLATE &
MARKINGS**

6.1 Name plate- On front door top left side-showing

- 1) Purchaser name & PO number.
- 2) Manufacturer name
- 3) Month / year of manufacturing
- 4) 'Property of Tata Power'
- 5) Feeder pillar serial number to be provided.

6) Separate metallic name plate with Tata Power Logo of Dimension 12*12 Inches in clear font as shown in Annexure-1.

7.0

TESTS

All routine, acceptance & type tests shall be carried out in accordance with the relevant IS/IEC. Following tests shall be necessarily conducted on the 'Sub Feeder Pillar' in addition to others specified in IS/IEC standards.

*In case of any conflict on any technical particular, the stricter requirement mentioned in the relevant standard shall be valid.



7.1

TYPE TEST

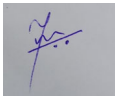

Type test - Only type tested components – Insulators & aluminium bus bar shall be accepted.

For Enclosure with busbar

Sr. No.	Test	Clause No.	Reference Standard
1	Verification of temperature-rise limits	Clause No 8.2	IS 5039
2	Verification of dielectric properties	Clause No 8.3	IS 5039

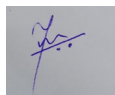

Rev No.	Description	Prepared By & Date	Checked By & Date	Approved for Issue By & Date
R00	TECHNICAL SPECIFICATION OF 8 Way Compact Sub feeder Pillar Panels	Yash M. Mane 	Ajay V. Potdar 	Ravindra M. Bhanage 
		22/12/2023	22/12/2023	22/12/2023

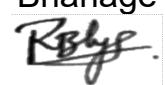
The Tata Power Company Ltd				TECHNICAL SPECIFICATION OF 8 Way Compact Sub feeder Pillar Panels	
ENSE-DS-2019-R00				Date of Issue: 22/12/2023	
		3	Verification of short-circuits strength	Clause No 8.4	IS 5039
		4	Verification of clearance and creepage distances	Clause No 8.5	IS 5039
		5	Verification of degree of protection	Clause No 8.6	IS 5039
7.2	ROUTINE TEST	1) Visual inspection & dimensional check 2) Insulation resistance test 3) HV test			
7.3	ACCEPTANCE TEST	1) Verification of clearance and creepage distance 2) Paint thickness check 3) Paint Shade 4) Wiring checks 5) Insulation resistance test 6) 1 unit from 1 st lot shall be tested for Temperature rise test with fuses. (Bidder to arrange for the same) 7) HV Test 8) Visual inspection & dimensional check			
8.0	TYPE TEST CERTIFICATES	<p>Bidder shall furnish the type test report of 'Feeder Pillar of same design' for the tests as mentioned in Clause no.7 of this specification as per reference standards. Complete set of Type Tests shall be conducted at CPRI/ERDA/NABL accredited laboratory. Type test should have been conducted in certified test laboratories during the period not exceeding 10 years from the date of opening the bid. any test report not acceptable or any/all type tests (including additional type tests, if any) not carried out, same shall be carried out without any cost implication to TATA POWER COMPANY.</p> <p>Type tests shall have been conducted in certified Test laboratories during the period not exceeding 10 years from the date of opening the bid. In case if type test conducted beyond 10 years then bidder to certify on letter head of parent OEM that no design change & no manufacturing plant change occurred from type tested product.</p> <p>In the event of any discrepancy in the test reports, i.e. any test report not acceptable or any/all type tests (including additional type tests, if any) not carried out, same shall be carried out without any cost implication to TATA POWER.</p> <p>Bidders shall submit Type Test Undertaking for conducting & submit report with 60 days of Outline Agreement.</p>			

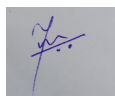

Rev No.	Description	Prepared By & Date	Checked By & Date	Approved for Issue By & Date
R00	TECHNICAL SPECIFICATION OF 8 Way Compact Sub feeder Pillar Panels	Yash M. Mane 	Ajay V. Potdar 	Ravindra M. Bhanage 
		22/12/2023	22/12/2023	22/12/2023

The Tata Power Company Ltd		TECHNICAL SPECIFICATION OF 8 Way Compact Sub feeder Pillar Panels
ENSE-DS-2019-R00		Date of Issue: 22/12/2023

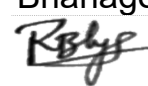
9.0	PRE-DESPATCH INSPECTION	<p>The Material shall be subject to inspection by a duly authorized representative of the TATA POWER COMPANY. Inspection may be made at any stage of manufacture at the discretion of the Purchaser and the equipment, if found unsatisfactory as to workmanship or material, the same is liable to rejection. Bidder shall always grant free access to the places of manufacture to TATA POWER COMPANY `s representatives when the work is in progress. Inspection by the TATA POWER COMPANY or its authorized representatives shall not relieve the Bidder of his obligation of furnishing equipment in accordance with the specifications. TATA POWER COMPANY authorized representatives shall have the right to inspect the design, materials and workmanship and to report thereon, at any stage of manufacture, if found necessary. All facilities shall be extended to our representatives for witnessing the tests. Due notice shall be given to us to enable us to depute our representatives for stage inspection. Material shall be dispatched after specific MDCC (Material Dispatch Clearance Certificate) is issued by TATA POWER COMPANY. Five certified copies of all test certificates including type tests, sample test certificates shall be sent to us for our approval prior to dispatch of materials.</p> <p>Following documents shall be sent along with material</p> <ol style="list-style-type: none"> Test reports MDCC issued by TATA POWER COMPANY Invoice in duplicate Packing list Drawings & catalogue Delivery Challan Other Documents (as applicable).
10.	INSPECTION AFTER RECEIPT AT STORES	<p>The material received at TATA POWER Store will be inspected for acceptance and shall be liable for rejection if found different from the reports of the pre-dispatch inspection and one copy of the report shall be sent to TATA POWER COMPANY.</p> <p>If any deviation or anomaly observed at this stage same need to be rectified by bidder at bidders own cost at earliest. The delay in rectification shall lead to any contractual penalty.</p>
11.0	GUARANTEE	<p>Bidder shall stand guarantee towards design, materials, workmanship & quality of process / manufacturing of items under this contract for due and intended performance of the same, as an integrated product delivered under this contract. In the event any defect is found by the Purchaser up to a period of at least 12 months from the date of commissioning or 24 months from the date of last supplies made under the contract whichever is earlier, Bidder shall be liable to undertake to replace/rectify such defects at its own costs, within mutually agreed time frame, and to the entire satisfaction of the Purchaser, failing which the Purchaser will be at liberty to get it replaced/rectified at Bidder's risks and costs and recover all such expenses plus the Purchaser's own charges (@ 20% of expenses incurred), from the Bidder or from the " Security cum Performance Deposit" as the case may be.</p> <p>In case of GP failure, BA shall report at site within 48 hours from intimation and arrange for rectification of fault within a mutually agreed time. In case rectification at site is not possible then alternative arrangement (replacement) to be made by BA within 15 days of intimation of failure.</p>

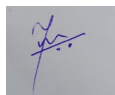

Rev No.	Description	Prepared By & Date	Checked By & Date	Approved for Issue By & Date
R00	TECHNICAL SPECIFICATION OF 8 Way Compact Sub feeder Pillar Panels	Yash M. Mane 	Ajay V. Potdar 	Ravindra M. Bhanage 
		22/12/2023	22/12/2023	22/12/2023

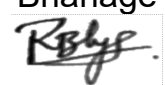
The Tata Power Company Ltd			TECHNICAL SPECIFICATION OF 8 Way Compact Sub feeder Pillar Panels
ENSE-DS-2019-R00			Date of Issue: 22/12/2023
		Bidder shall further be responsible for 'free replacement' for another period of THREE years from the end of the guarantee period for any 'Latent Defects' if noticed and reported by the Purchaser.	
12.0	PACKING AND TRANSPORT	<p>Bidder shall ensure that the item covered under this specification shall be packaged for rail/road transport in a manner so as to protect the equipment from damage in transit. The material used for packing shall be environmentally friendly.</p> <p>No single use plastic to be used in packing material. Packing should be done with environment friendly recyclable materials.</p>	
13.0	TENDER SAMPLE	Not applicable.	
14.0	QUALITY CONTROL	<p>The Bidder shall submit with the offer Quality assurance plan indicating the various stages of inspection, the tests and checks which will be carried out on the material of construction, components during manufacture and bought out items and fully assembled component and equipment after finishing. As part of the plan, a schedule for stage and final inspection within the parameters of the delivery schedule shall be furnished.</p> <p>TATA POWER COMPANY shall reserve the sole rights for the type test of a random sample from the lot and in case of any discrepancy or deviation from the Type test certificates submitted along with the Bid; the complete Lot shall be rejected.</p> <p>TATA POWER COMPANY representative or its nominated representative shall have free access to the Bidder's works to carry out inspections.</p> <p>If anything missing in QAP and required as per other clauses of this document, bidder is liable to perform the same without cost implication.</p>	
15.0	MINIMUM TESTING FACILITIES	Bidder shall have adequate in-house testing facilities for carrying out all routine tests & acceptance tests as per relevant International / Indian standards	
16.0	MANUFACTURING ACTIVITIES	The successful bidder will have to submit first GTP & Drawing with 7 days from placement of outline agreement for approval and complete the approval process within 14 days of outline agreement. The date of Code -2/ Code-1 approval given by TATA Power will be treated as first day for assessment of LD (if applicable).	
17.0	SPARES, ACCESSORIES AND TOOLS	Keys of door, 1 set of Fuse Puller with every 30 units.	

Rev No.	Description	Prepared By & Date	Checked By & Date	Approved for Issue By & Date
R00	TECHNICAL SPECIFICATION OF 8 Way Compact Sub feeder Pillar Panels	Yash M. Mane 	Ajay V. Potdar 	Ravindra M. Bhanage 
		22/12/2023	22/12/2023	22/12/2023

The Tata Power Company Ltd		TECHNICAL SPECIFICATION OF 8 Way Compact Sub feeder Pillar Panels
ENSE-DS-2019-R00		Date of Issue: 22/12/2023

18.0	DRAWINGS AND DOCUMENTS	<p>Following drawings and documents shall be prepared based on TATA POWER COMPANY specifications and statutory requirements and shall be submitted with the bid. All the documents & drawings shall be in English language</p> <p>a) Completely filled in Technical Particulars b) General description of the equipment and all components including brochures. c) General arrangement drawing. d) Bill of material e) Experience List f) Type test certificates g) Any other technical document, if required</p>						
19.0	SCHEDULE "A" GUARANTEED TECHNICAL PARTICULARS:	Clause wise compliance of this specification is to be submitted with bid documents.						
20.0	SCHEDULE "B" DEVIATIONS	<p align="center"><u>(TO BE ENCLOSED WITH TECHNICAL BID)</u></p> <p>All deviations from this specification shall be set out by the Bidders, clause by Clause in this schedule. Unless specifically mentioned in this Schedule, the tender shall be deemed to confirm the purchaser's specifications:</p> <table border="1"> <thead> <tr> <th>S.No.</th> <th>Clause No.</th> <th>Details of deviation with justifications</th> </tr> </thead> <tbody> <tr> <td> </td> <td> </td> <td> </td> </tr> </tbody> </table> <p>We confirm that there are no deviations apart from those detailed above.</p> <p>Seal of the Company:</p> <p>Designation</p> <p>Signature</p>	S.No.	Clause No.	Details of deviation with justifications			
S.No.	Clause No.	Details of deviation with justifications						

Rev No.	Description	Prepared By & Date	Checked By & Date	Approved for Issue By & Date
R00	TECHNICAL SPECIFICATION OF 8 Way Compact Sub feeder Pillar Panels	Yash M. Mane  22/12/2023	Ajay V. Potdar  22/12/2023	Ravindra M. Bhanage  22/12/2023

The Tata Power Company Ltd		TECHNICAL SPECIFICATION OF 8 Way Compact Sub feeder Pillar Panels
ENSE-DS-2019-R00		Date of Issue: 22/12/2023

Annexure – I

Tata power Branding Name plate -

Separate metallic name plate with Tata Power Logo of Dimension 12*12 Inches in clear font as shown below.

Relationship between the two marks- size

The Tata and Tata Power Marks are always used in conjunction with each other, never appearing in isolation on Tata Power communication.

The height of the letter T of Tata (T-height) is the basic measure for all sizes and proportions.

The rounded measure 2T in height, is separated from the Tata lettering by a distance of 1/2T.

The T height of both, the Tata and the Tata Power Marks is to be the same, except in exceptional cases on approval from the Corporate Communications team.

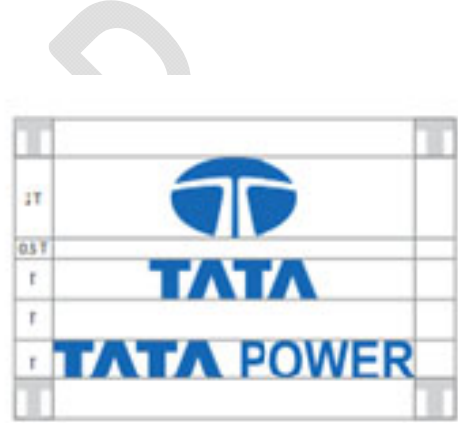



Relationship between the two marks- positioning

The two marks can appear stacked, which is the preferred placement, or linear, by the side of one another.

Centre aligned - Stacked (Preferred)





Rev No.	Description	Prepared By & Date	Checked By & Date	Approved for Issue By & Date
R00	TECHNICAL SPECIFICATION OF 8 Way Compact Sub feeder Pillar Panels	Yash M. Mane 	Ajay V. Potdar 	Ravindra M. Bhanage 
		22/12/2023	22/12/2023	22/12/2023

The Tata Power Company Ltd		TECHNICAL SPECIFICATION OF 8 Way Compact Sub feeder Pillar Panels
ENSE-DS-2019-R00		Date of Issue: 22/12/2023

Annexure 2: Inspection Testing Plan

- 1) Verification of clearance and creepage distance
- 2) Paint thickness check
- 3) Paint Shade
- 4) Wiring checks
- 5) Insulation resistance test
- 6) 1 unit from 1st lot shall be tested for Temperature rise test with fuses. (Bidder to arrange for the same)
- 7) HV Test
- 8) Visual inspection & dimensional check

TATA POWER

Rev No.	Description	Prepared By & Date	Checked By & Date	Approved for Issue By & Date
R00	TECHNICAL SPECIFICATION OF 8 Way Compact Sub feeder Pillar Panels	Yash M. Mane 	Ajay V. Potdar 	Ravindra M. Bhanage 
		22/12/2023	22/12/2023	22/12/2023

The Tata Power Company Ltd		TECHNICAL SPECIFICATION OF Mini Pillar-with Fuses 415V, 400A
ENSE-DS-2020-R00		Date of Issue: 22/12/2023

TECHNICAL SPECIFICATION

Mini Pillar with Fuses - 415 V, 400A



*The Tata Power Company Ltd.
Engineering Services (ENSE),
Distribution Division,
Senapati Bapat Marg,
Lower Parel,
Mumbai – 40013
Maharashtra*



The Tata Power Company Ltd		TECHNICAL SPECIFICATION OF Mini Pillar with Fuses- 415V, 400A
ENSE-DS-2020-R00		Date of Issue: 22/12/2023

TECHNICAL SPECIFICATION COVER SHEET

Document No: ENSE-DS-2020-R00

Document Title: Technical Specification of Mini Pillar with Fuses- 415V, 400A

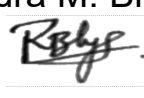

R00	ENSE-DS-2020-R00 For tendering Purpose	22/12/2023	YMM		AVP		RMB	
R0	SPEC NET Mini Pillar with Fuse-01	20/06/2017	ND	-sd-	SK	-sd-	CC	-sd-
Rev No.	Remarks	Date	Initials	Sign	Initials	Sign	Initials	Sign
			Prepared By		Reviewed By		Approved & Issued By	

Rev No.	Description	Prepared By & Date	Checked By & Date	Approved for Issue By & Date
R00	TECHNICAL SPECIFICATION OF Mini Pillar with Fuses 415 V, 400 A	Yash M. Mane 	Ajay V. Potdar 	Ravindra M. Bhanage 
		22/12/2023	22/12/2023	22/12/2023

The Tata Power Company Ltd		TECHNICAL SPECIFICATION OF Mini Pillar with Fuses- 415V, 400A
ENSE-DS-2020-R00		Date of Issue: 22/12/2023



CONTENTS

- 1.0 SCOPE
 - 2.0 APPLICABLE STANDARDS
 - 3.0 CLIMATIC CONDITIONS OF THE INSTALLATION
 - 4.0 GENERAL TECHNICAL REQUIREMENTS
 - 5.0 GENERAL CONSTRUCTIONS
 - 6.0 NAME PLATE & MARKINGS
 - 7.0 TESTS
 - 8.0 TYPE TEST CERIFICATES
 - 9.0 PRE-DISPATCH INSPECTION
 - 10.0 INSPECTION AFTER RECEIPT AT STORE
 - 11.0 GUARANTEE
 - 12.0 PACKING AND TRANSPORT
 - 13.0 TENDER SAMPLE
 - 14.0 QUALITY CONTROL
 - 15.0 MINIMUM TESTING FACILITIES
 - 16.0 MANUFACTURING ACTIVITIES
 - 17.0 SPARES, ACCESSORIES AND TOOLS
 - 18.0 DRAWING AND DOCUMENTS
 - 19.0 SCHEDULE "A" GUARANTEED TECHNICAL PARTICULARS
 - 20.0 SCHEDULE "B" DEVIATIONS
- + ANNEXURE 1 & 2

Rev No.	Description	Prepared By & Date	Checked By & Date	Approved for Issue By & Date
R00	TECHNICAL SPECIFICATION OF Mini Pillar with Fuses 415 V, 400 A	Yash M. Mane 	Ajay V. Potdar 	Ravindra M. Bhanage 
		22/12/2023	22/12/2023	22/12/2023



The Tata Power Company Ltd		TECHNICAL SPECIFICATION OF Mini Pillar with Fuses- 415V, 400A
ENSE-DS-2020-R00		Date of Issue: 22/12/2023

1.0	SCOPE	<p>This specification covers design, engineering, manufacture; shop testing, inspection, painting, packing, and supply of 415V Mini Pillar with fuses complete with all accessories for efficient and trouble-free operation of the distribution network for Tata Power Company Ltd. at Mumbai.</p> <p>It is not our intent to specify completely herein all details of design and construction of the equipment. However, the equipment shall conform in all respects to high standards of Engineering design and workmanship and shall be capable of performing in a manner acceptable to the Purchaser (Tata Power Company) who will interpret the meaning of drawings and specification and shall be entitled to reject any work or material which in his judgement is not in full accordance therewith.</p> <p>All the bought-out items shall be of reputed make and shall be subject to approval by the Purchaser (Tata Power Company) after award of contract. All Sub vendor/Subcontractor list shall also be subject to approval by the Purchaser (Tata Power Company) after award of contract.</p>																						
2.0	APPLICABLE STANDARDS	<p>The equipment (and the materials used) covered by this specification shall unless otherwise stated, be designed, manufactured and tested in accordance with the latest editions of the following Indian, IEC / International standards , with latest amendment from time to time, thereof, some of which are listed below:</p> <p>The Sub Feeder Pillar shall comply with the requirements stated in the latest editions of the following recommendations, standard and specifications:</p> <table border="1" data-bbox="424 1034 1449 1827"> <thead> <tr> <th data-bbox="424 1034 759 1106">INDIAN STANDARDS (IS)</th> <th data-bbox="759 1034 1449 1106">Title</th> </tr> </thead> <tbody> <tr> <td data-bbox="424 1106 759 1155">IS 5039</td> <td data-bbox="759 1106 1449 1155">Specification for distribution pillars below 1000V AC</td> </tr> <tr> <td data-bbox="424 1155 759 1211">IS 5</td> <td data-bbox="759 1155 1449 1211">Colour of ready mixed paints and enamels</td> </tr> <tr> <td data-bbox="424 1211 759 1267">IS 191</td> <td data-bbox="759 1211 1449 1267">Copper Specification</td> </tr> <tr> <td data-bbox="424 1267 759 1384">IS 13703-2</td> <td data-bbox="759 1267 1449 1384">Low voltage fuses for voltage not exceeding 1000 V AC or 1500 V DC. Part 2 - Fuses for use by authorized persons</td> </tr> <tr> <td data-bbox="424 1384 759 1489">IS 5082</td> <td data-bbox="759 1384 1449 1489">Wrought aluminium and aluminium alloy bars, rods, tubes, sections, plates and sheets for electrical applications</td> </tr> <tr> <td data-bbox="424 1489 759 1545">IS 1359</td> <td data-bbox="759 1489 1449 1545">Electroplated Coatings of Tin</td> </tr> <tr> <td data-bbox="424 1545 759 1624">IS 1730</td> <td data-bbox="759 1545 1449 1624">Dimensions for steel plates, sheets strips and flats for general engineering purposes</td> </tr> <tr> <td data-bbox="424 1624 759 1680">IS 2551</td> <td data-bbox="759 1624 1449 1680">Danger Notice plates</td> </tr> <tr> <td data-bbox="424 1680 759 1758">IS 4759</td> <td data-bbox="759 1680 1449 1758">Hot-dip Zinc coatings on structural steel and other allied products</td> </tr> <tr> <td data-bbox="424 1758 759 1827">IS 14772</td> <td data-bbox="759 1758 1449 1827">General requirements for enclosures for accessories for household and similar fixed electrical installations</td> </tr> </tbody> </table>	INDIAN STANDARDS (IS)	Title	IS 5039	Specification for distribution pillars below 1000V AC	IS 5	Colour of ready mixed paints and enamels	IS 191	Copper Specification	IS 13703-2	Low voltage fuses for voltage not exceeding 1000 V AC or 1500 V DC. Part 2 - Fuses for use by authorized persons	IS 5082	Wrought aluminium and aluminium alloy bars, rods, tubes, sections, plates and sheets for electrical applications	IS 1359	Electroplated Coatings of Tin	IS 1730	Dimensions for steel plates, sheets strips and flats for general engineering purposes	IS 2551	Danger Notice plates	IS 4759	Hot-dip Zinc coatings on structural steel and other allied products	IS 14772	General requirements for enclosures for accessories for household and similar fixed electrical installations
INDIAN STANDARDS (IS)	Title																							
IS 5039	Specification for distribution pillars below 1000V AC																							
IS 5	Colour of ready mixed paints and enamels																							
IS 191	Copper Specification																							
IS 13703-2	Low voltage fuses for voltage not exceeding 1000 V AC or 1500 V DC. Part 2 - Fuses for use by authorized persons																							
IS 5082	Wrought aluminium and aluminium alloy bars, rods, tubes, sections, plates and sheets for electrical applications																							
IS 1359	Electroplated Coatings of Tin																							
IS 1730	Dimensions for steel plates, sheets strips and flats for general engineering purposes																							
IS 2551	Danger Notice plates																							
IS 4759	Hot-dip Zinc coatings on structural steel and other allied products																							
IS 14772	General requirements for enclosures for accessories for household and similar fixed electrical installations																							

Rev No.	Description	Prepared By & Date	Checked By & Date	Approved for Issue By & Date
R00	TECHNICAL SPECIFICATION OF Mini Pillar with Fuses 415 V, 400 A	Yash M. Mane  22/12/2023	Ajay V. Potdar  22/12/2023	Ravindra M. Bhanage  22/12/2023



The Tata Power Company Ltd		TECHNICAL SPECIFICATION OF Mini Pillar with Fuses- 415V, 400A
ENSE-DS-2020-R00		Date of Issue: 22/12/2023

		<table border="1"> <thead> <tr> <th>IEC STANDARDS</th> <th>Title</th> </tr> </thead> <tbody> <tr> <td>IEC TR 61439-0</td> <td>Low-voltage switchgear and controlgear assemblies- Part 0: Guidance to specifying assemblies</td> </tr> <tr> <td>IEC 61439-1</td> <td>Low-voltage switchgear and controlgear assemblies Part 1: General rules</td> </tr> <tr> <td>IEC 60947-3</td> <td>Low-voltage switchgear and controlgear - Part 3: Switches, disconnectors, switch-disconnectors and fuse-combination units.</td> </tr> <tr> <td>IEC 60947-1</td> <td>Low-voltage switchgear and controlgear - Part 1: General rules</td> </tr> <tr> <td>IEC 60664</td> <td>Insulation coordination for equipment within low-voltage systems - ALL PARTS</td> </tr> <tr> <td>IEC 60269-1</td> <td>Low-Voltage Fuses Part 1 General Requirements</td> </tr> <tr> <td>IEC 61439-2</td> <td>Low-voltage switchgear and controlgear assemblies Part 2: Power switchgear and controlgear assemblies</td> </tr> <tr> <td>IEC 60529</td> <td>Degrees of protection provided by enclosures (IP Code)</td> </tr> </tbody> </table> <p>In case of any conflict on any technical particular in the specification, the stricter requirement mentioned in the relevant standard shall be valid.</p>	IEC STANDARDS	Title	IEC TR 61439-0	Low-voltage switchgear and controlgear assemblies- Part 0: Guidance to specifying assemblies	IEC 61439-1	Low-voltage switchgear and controlgear assemblies Part 1: General rules	IEC 60947-3	Low-voltage switchgear and controlgear - Part 3: Switches, disconnectors, switch-disconnectors and fuse-combination units.	IEC 60947-1	Low-voltage switchgear and controlgear - Part 1: General rules	IEC 60664	Insulation coordination for equipment within low-voltage systems - ALL PARTS	IEC 60269-1	Low-Voltage Fuses Part 1 General Requirements	IEC 61439-2	Low-voltage switchgear and controlgear assemblies Part 2: Power switchgear and controlgear assemblies	IEC 60529	Degrees of protection provided by enclosures (IP Code)														
		IEC STANDARDS	Title																															
IEC TR 61439-0	Low-voltage switchgear and controlgear assemblies- Part 0: Guidance to specifying assemblies																																	
IEC 61439-1	Low-voltage switchgear and controlgear assemblies Part 1: General rules																																	
IEC 60947-3	Low-voltage switchgear and controlgear - Part 3: Switches, disconnectors, switch-disconnectors and fuse-combination units.																																	
IEC 60947-1	Low-voltage switchgear and controlgear - Part 1: General rules																																	
IEC 60664	Insulation coordination for equipment within low-voltage systems - ALL PARTS																																	
IEC 60269-1	Low-Voltage Fuses Part 1 General Requirements																																	
IEC 61439-2	Low-voltage switchgear and controlgear assemblies Part 2: Power switchgear and controlgear assemblies																																	
IEC 60529	Degrees of protection provided by enclosures (IP Code)																																	
3.0	<p>CLIMATIC CONDITIONS OF THE INSTALLATION</p> <table border="1"> <tbody> <tr><td>1</td><td>Maximum ambient temperature</td><td>43 deg.C</td></tr> <tr><td>2</td><td>Max. Daily average ambient temp</td><td>35 deg.C</td></tr> <tr><td>3</td><td>Min Ambient Temperature</td><td>07 deg.C</td></tr> <tr><td>4</td><td>Maximum Relative Humidity</td><td>100%</td></tr> <tr><td>5</td><td>Minimum Relative Humidity</td><td>40%</td></tr> <tr><td>6</td><td>Average No. of thunderstorm per annum</td><td>50</td></tr> <tr><td>7</td><td>Average Annual Rainfall</td><td>2380mm</td></tr> <tr><td>8</td><td>Average No. of rainy days per annum</td><td>115</td></tr> <tr><td>9</td><td>Rainy months</td><td>June to Oct.</td></tr> <tr><td>10</td><td>Altitude above MSL not exceeding</td><td>300 meters</td></tr> <tr><td>11</td><td>Average Air Pressure</td><td>29.6-inch Hg</td></tr> </tbody> </table> <p>Atmosphere is generally laden with mild acid and dust suspended during summer months and subjected to fog in winter months. The design of the equipment and accessories shall be suitable to withstand seismic forces corresponding to an acceleration of 0.1g.</p>	1	Maximum ambient temperature	43 deg.C	2	Max. Daily average ambient temp	35 deg.C	3	Min Ambient Temperature	07 deg.C	4	Maximum Relative Humidity	100%	5	Minimum Relative Humidity	40%	6	Average No. of thunderstorm per annum	50	7	Average Annual Rainfall	2380mm	8	Average No. of rainy days per annum	115	9	Rainy months	June to Oct.	10	Altitude above MSL not exceeding	300 meters	11	Average Air Pressure	29.6-inch Hg
1	Maximum ambient temperature	43 deg.C																																
2	Max. Daily average ambient temp	35 deg.C																																
3	Min Ambient Temperature	07 deg.C																																
4	Maximum Relative Humidity	100%																																
5	Minimum Relative Humidity	40%																																
6	Average No. of thunderstorm per annum	50																																
7	Average Annual Rainfall	2380mm																																
8	Average No. of rainy days per annum	115																																
9	Rainy months	June to Oct.																																
10	Altitude above MSL not exceeding	300 meters																																
11	Average Air Pressure	29.6-inch Hg																																

Rev No.	Description	Prepared By & Date	Checked By & Date	Approved for Issue By & Date
R00	TECHNICAL SPECIFICATION OF Mini Pillar with Fuses 415 V, 400 A	Yash M. Mane 	Ajay V. Potdar 	Ravindra M. Bhanage 
		22/12/2023	22/12/2023	22/12/2023



The Tata Power Company Ltd		TECHNICAL SPECIFICATION OF Mini Pillar with Fuses- 415V, 400A
ENSE-DS-2020-R00		Date of Issue: 22/12/2023

4.0	GENERAL TECHNICAL REQUIREMENTS	<table border="1"> <thead> <tr> <th>Sr. No.</th> <th>Item Description</th> <th>Tata Power Requirement</th> </tr> </thead> <tbody> <tr> <td rowspan="3">1</td> <td rowspan="3">Manufacturer</td> <td>Name</td> </tr> <tr> <td>Manufacturer Address</td> </tr> <tr> <td>Contact telephone no</td> </tr> <tr> <td>2</td> <td>Main bus bar rating</td> <td>500A</td> </tr> <tr> <td rowspan="2">3</td> <td rowspan="2">No of incoming feeders</td> <td>Quantity-1Nos</td> </tr> <tr> <td>Rating in Amp- 315A</td> </tr> <tr> <td rowspan="2">4</td> <td rowspan="2">No of outgoing feeders</td> <td>Quantity-04nos</td> </tr> <tr> <td>Rating in Amp- 160A</td> </tr> <tr> <td>5</td> <td>Panel construction</td> <td>CRCA sheet steel</td> </tr> <tr> <td>6</td> <td>Panel enclosure class</td> <td>IP54 - ingress protection (for outdoor installation)</td> </tr> <tr> <td>7</td> <td>Sheet thickness</td> <td>3 mm minimum for covers & canopy, 2.5 mm for doors(As per IS 5039)</td> </tr> <tr> <td>8</td> <td>Pedestal for mini pillar</td> <td>Of height 270 mm with side covers of FRP sheet painted in matt black</td> </tr> <tr> <td>9</td> <td>Door type for front & rear access</td> <td>Single door for mini pillar</td> </tr> <tr> <td>10</td> <td>Door hinges</td> <td>Three anti theft type hinges</td> </tr> <tr> <td>11</td> <td>Padlocking facility</td> <td>As per Specification</td> </tr> <tr> <td rowspan="2">12</td> <td rowspan="2">Master key for all doors</td> <td>Identical for all panels,</td> </tr> <tr> <td>1 no./ panel</td> </tr> <tr> <td>13</td> <td>External steel hardware</td> <td>Galvanized nut & bolts, yellow zinc plated 8.8 Grade for Electrical Contacts. Other Hardware grade 4.6</td> </tr> <tr> <td>14</td> <td>Phase & neutral Bus bar</td> <td>Aluminum grade 19501 (H2) as per IS 5082</td> </tr> <tr> <td>15</td> <td>Bus bar color coding for R,Y, B & neutral</td> <td>Heat shrinkable sleeves with color Red, Yellow, Blue & Black respectively</td> </tr> <tr> <td>16</td> <td>Bus bar size in mm</td> <td>1x50x10mm for Phase & Neutral (Al)</td> </tr> <tr> <td>17</td> <td>Earth bus size</td> <td>50x6mm GI</td> </tr> <tr> <td>18</td> <td>Main bus bar short circuit withstand capacity</td> <td>Above 50kA for 1 sec as per IEC 61439</td> </tr> <tr> <td>19</td> <td>Main bus bar maximum temperature rise</td> <td>Busbar: 45 deg C Terminals: 65 deg C</td> </tr> <tr> <td>20</td> <td>Bus bar support insulators</td> <td>As per IS13410 SMC / DMC, 1100V grade</td> </tr> </tbody> </table>	Sr. No.	Item Description	Tata Power Requirement	1	Manufacturer	Name	Manufacturer Address	Contact telephone no	2	Main bus bar rating	500A	3	No of incoming feeders	Quantity-1Nos	Rating in Amp- 315A	4	No of outgoing feeders	Quantity-04nos	Rating in Amp- 160A	5	Panel construction	CRCA sheet steel	6	Panel enclosure class	IP54 - ingress protection (for outdoor installation)	7	Sheet thickness	3 mm minimum for covers & canopy, 2.5 mm for doors(As per IS 5039)	8	Pedestal for mini pillar	Of height 270 mm with side covers of FRP sheet painted in matt black	9	Door type for front & rear access	Single door for mini pillar	10	Door hinges	Three anti theft type hinges	11	Padlocking facility	As per Specification	12	Master key for all doors	Identical for all panels,	1 no./ panel	13	External steel hardware	Galvanized nut & bolts, yellow zinc plated 8.8 Grade for Electrical Contacts. Other Hardware grade 4.6	14	Phase & neutral Bus bar	Aluminum grade 19501 (H2) as per IS 5082	15	Bus bar color coding for R,Y, B & neutral	Heat shrinkable sleeves with color Red, Yellow, Blue & Black respectively	16	Bus bar size in mm	1x50x10mm for Phase & Neutral (Al)	17	Earth bus size	50x6mm GI	18	Main bus bar short circuit withstand capacity	Above 50kA for 1 sec as per IEC 61439	19	Main bus bar maximum temperature rise	Busbar: 45 deg C Terminals: 65 deg C	20	Bus bar support insulators	As per IS13410 SMC / DMC, 1100V grade
		Sr. No.	Item Description	Tata Power Requirement																																																																		
		1	Manufacturer	Name																																																																		
				Manufacturer Address																																																																		
				Contact telephone no																																																																		
		2	Main bus bar rating	500A																																																																		
		3	No of incoming feeders	Quantity-1Nos																																																																		
				Rating in Amp- 315A																																																																		
		4	No of outgoing feeders	Quantity-04nos																																																																		
				Rating in Amp- 160A																																																																		
		5	Panel construction	CRCA sheet steel																																																																		
		6	Panel enclosure class	IP54 - ingress protection (for outdoor installation)																																																																		
		7	Sheet thickness	3 mm minimum for covers & canopy, 2.5 mm for doors(As per IS 5039)																																																																		
		8	Pedestal for mini pillar	Of height 270 mm with side covers of FRP sheet painted in matt black																																																																		
		9	Door type for front & rear access	Single door for mini pillar																																																																		
		10	Door hinges	Three anti theft type hinges																																																																		
		11	Padlocking facility	As per Specification																																																																		
		12	Master key for all doors	Identical for all panels,																																																																		
				1 no./ panel																																																																		
		13	External steel hardware	Galvanized nut & bolts, yellow zinc plated 8.8 Grade for Electrical Contacts. Other Hardware grade 4.6																																																																		
14	Phase & neutral Bus bar	Aluminum grade 19501 (H2) as per IS 5082																																																																				
15	Bus bar color coding for R,Y, B & neutral	Heat shrinkable sleeves with color Red, Yellow, Blue & Black respectively																																																																				
16	Bus bar size in mm	1x50x10mm for Phase & Neutral (Al)																																																																				
17	Earth bus size	50x6mm GI																																																																				
18	Main bus bar short circuit withstand capacity	Above 50kA for 1 sec as per IEC 61439																																																																				
19	Main bus bar maximum temperature rise	Busbar: 45 deg C Terminals: 65 deg C																																																																				
20	Bus bar support insulators	As per IS13410 SMC / DMC, 1100V grade																																																																				

Rev No.	Description	Prepared By & Date	Checked By & Date	Approved for Issue By & Date
R00	TECHNICAL SPECIFICATION OF Mini Pillar with Fuses 415 V, 400 A	Yash M. Mane 	Ajay V. Potdar 	Ravindra M. Bhanage 
		22/12/2023	22/12/2023	22/12/2023



The Tata Power Company Ltd		TECHNICAL SPECIFICATION OF Mini Pillar with Fuses- 415V, 400A
ENSE-DS-2020-R00		Date of Issue: 22/12/2023

		21	Incoming Cable provision	4C 300 Sq.mm
		22	Outgoing Cable provision	4C 185 Sq.mm
		23	Fuse Base	4 no. 160A, Type 1 Per Phase (for Outgoing)
		24	Make (Fuse Base & Fuse Links)	Schneider/ L&T/ Siemens/ GE Power Controls/ HPL/ Havells/ Jean Muller / Bussman.
		25	Fuses (160A)	HRC plug-in type
		26	Gland plate at panel bottom	MS, Black powder coated, 3mm thick for Multi core cable.
		27	Cable termination clearance	300mm minimum from gland plate
		28	Earth studs on both side of panel bottom	With M10 galvanized steel nut bolts
		29	Panel maximum dimensions in mm Mini Pillar with Fuses in mm	Width X Depth X Height 650 X 400 X 1766
		30	Clearance between live parts minimum 25mm(As per IS/IEC 60947 (Part 1))	Phase - phase & Phase - earth
		31	Continuous rated operating voltage	440 volt +/- 10%
		32	High voltage withstand capacity (Verification as per IS/IEC 61439 (Part 2))	2000 volt at 50 Hz for 1minute
		33	Insulation resistance ph-ph & ph-earth	Minimum 10MOhm with 500V Megger
		34	Labels & name plates	As per specification
		35	Surface preparation for painting	Sand blasting or 7 tank process
		36	Painting	Power coated grade A PU min thickness 120 micron
		37	Shade	International Orange shade No 592 of IS-5
		38	Fluorescent strip	2 Nos. retro reflective sticker 3M or paint (should reflect vehicular lights during night) strips of Yellow colour each of 75 mm width shall be provided on all sides.
		39	Panel drawing	Refer drawing
		40	Type Test certificate	Type Test to be conducted on one unit of this design.

Rev No.	Description	Prepared By & Date	Checked By & Date	Approved for Issue By & Date
R00	TECHNICAL SPECIFICATION OF Mini Pillar with Fuses 415 V, 400 A	Yash M. Mane 	Ajay V. Potdar 	Ravindra M. Bhanage 
		22/12/2023	22/12/2023	22/12/2023



The Tata Power Company Ltd		TECHNICAL SPECIFICATION OF Mini Pillar with Fuses- 415V, 400A
ENSE-DS-2020-R00		Date of Issue: 22/12/2023

5.0	GENERAL CONSTRUCTION	Mini pillar with Fuses - TPN Bus bar with 1 hole (for incomer) & 4 fuses (for outgoing).		
		Sr. No.	Parameter	Requirement
		1	Basic Design	A totally enclosed free standing floor mounted self-supporting metal sheet cubical containing bus-bars connected to distribution feeders.
		2	Number of Ways	The maximum number of circuits for which the mini pillar with fuses shall be designed: Mini Pillar with Fuses: 5 Way
		3	Neutral bus	At bottom of panel, with M10 Nut- Bolts for terminating incoming & outgoing Mini Pillar cable neutral circuit
		4	Earth Bus	Earth strip of 50X6mm GI
		A. Enclosure:		
		Sr. No.	Parameter	Requirement
		1	Application	Outdoor type
		2	Material	Cold Rolled Close Annealed (CRCA) sheet steel - powder coated.
3	Thickness of enclosure	3 mm. Able to withstand rough weather conditions.		
4	Finishing of enclosure	Pre-treated & powder coating minimum 120 microns at any point of measurement		
5	Design	Compact and enclosure shall be designed to facilitate easy maintenance at a minimum height of 270 mm above FFL		
6	Design at top	Sloping canopy at top so that rain water does not accumulate.		
		Minimum 10 degree slanting slope and extended 50 mm outside		
		Lifting lug- 2 nos. lug welded on top. Eyebolt of suitable sizes shall be provided for lifting arrangements.		
7	Degree of Protection	IP54 suitable for outdoor installation		
8	Gland plate at panel bottom	Mild Steel 3 mm thick		
		Removable detachable base plate. It shall be possible to temporarily detach the base plate for installation and connection of cables.		
		SS nuts and bolts.		

Rev No.	Description	Prepared By & Date	Checked By & Date	Approved for Issue By & Date
R00	TECHNICAL SPECIFICATION OF Mini Pillar with Fuses 415 V, 400 A	Yash M. Mane 	Ajay V. Potdar 	Ravindra M. Bhanage 
		22/12/2023	22/12/2023	22/12/2023



The Tata Power Company Ltd		TECHNICAL SPECIFICATION OF Mini Pillar with Fuses- 415V, 400A
ENSE-DS-2020-R00		Date of Issue: 22/12/2023

		9	Fluorescent strip / painting on panel	<p>2 Nos. retro reflective sticker 3M (should reflect vehicular lights during night) strips of yellow colour each of 75 mm width shall be provided on all sides.</p> <p>Paint shall have good colour retention, UV and weather resistant</p> <p>"STICK NO BILLS" to be painted on both sides of the Compact Sub Feeder Pillar with Black Colour on Yellow Background.</p>						
		10	Dimensions (max)	<table border="1" style="margin-left: auto; margin-right: auto;"> <tr> <td style="text-align: center;">Width</td> <td style="text-align: center;">Depth</td> <td style="text-align: center;">Height</td> </tr> <tr> <td style="text-align: center;">650</td> <td style="text-align: center;">400</td> <td style="text-align: center;">1766</td> </tr> </table>	Width	Depth	Height	650	400	1766
Width	Depth	Height								
650	400	1766								
		11	Stand	<p>Legs - Iron angle of 40 x 40 x 5 mm at each corner and also hot dipped galvanized</p> <p>Height of leg 250 mm</p> <p>Welded plate at bottom of each leg should have hole of at least 21 mm for fixing of foundation bolt.</p> <p>Bottom holes on four sides- Oval shape, for grouting bolts</p>						
		12	Louvers	<p>The panel shall be of dust and vermin proof construction and of self-cooled design with adequate louvers on side's portion. The louvers shall have fine wire mesh. Vermin Proof should be done with gaskets.</p> <p>(Minimum 2 Nos on each sides)</p>						
		13	Paint shade	<p>International Orange shade No 592 of IS-5 with minimum 120 microns thickness. Good retention and UV & weather resistant paint.</p>						
		14	Surface preparation for painting	<p>Sand blasting or 7 tank process followed by powder coating</p>						
		15	Foundation Bolts	<p>Required Number of Foundation Bolts to be supplied with the panel.</p>						
		16	External hardware	<p>Galvanized steel nut & bolts, Yellow zinc plated with grade 8.8 for Electrical contacts. Other hardware of grade 4.6</p>						
		17	Bolted Covers	<p>Panel Should have internally bolted, removable back cover with handles.</p>						
		18	Insulation sheets	<p>All enclosure shall be covered with bolted min 1.5 mm thick SMC/FRP sheets from inside.</p>						

Rev No.	Description	Prepared By & Date	Checked By & Date	Approved for Issue By & Date
R00	TECHNICAL SPECIFICATION OF Mini Pillar with Fuses 415 V, 400 A	Yash M. Mane 	Ajay V. Potdar 	Ravindra M. Bhanage 
		22/12/2023	22/12/2023	22/12/2023

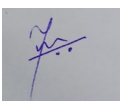

The Tata Power Company Ltd		TECHNICAL SPECIFICATION OF Mini Pillar with Fuses- 415V, 400A
ENSE-DS-2020-R00		Date of Issue: 22/12/2023

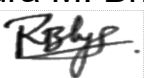
		<p>B. Doors:</p> <table border="1" data-bbox="422 331 1468 1406"> <thead> <tr> <th>Sr. No.</th> <th>Parameter</th> <th>Requirement</th> </tr> </thead> <tbody> <tr> <td>1</td> <td>Material of door</td> <td>Cold Rolled Close Annealed (CRCA) sheet steel - powder coated.</td> </tr> <tr> <td>2</td> <td>Thickness</td> <td>Thickness - 2.5 mm</td> </tr> <tr> <td>3</td> <td>Type of Door arrangement</td> <td>The door shall be so fitted as to provide the interior with maximum protection from atmospheric conditions.</td> </tr> <tr> <td>4</td> <td>Insulation</td> <td>For Mini pillar with Fuses front access Single door All doors shall be covered with min 1.5 mm thick SMC/FRP sheets.</td> </tr> <tr> <td>5</td> <td>Hinges</td> <td>Minimum 3 Nos. anti-theft hinges for each door. Hinges shall not be visible from outside and should not be removable. Material of hinges and screws: Heavy duty stainless steel (SS) Hinges shall be of such construction that the doors can be swung open by not less than 120 deg.</td> </tr> <tr> <td>6</td> <td>Engraving</td> <td>SLD shall be engraved & pasted on inside part of door</td> </tr> <tr> <td>7</td> <td>Gasket</td> <td>The panel shall be provided with gasket all round the perimeter of covers, gland plates, removable covers and doors</td> </tr> <tr> <td>8</td> <td>Door handles</td> <td>On front</td> </tr> <tr> <td>9</td> <td>Paint shade</td> <td>International Orange shade No 592 of IS-5 with minimum 120 microns thickness. Good retention and UV & weather resistant paint. 2 Nos. retro reflective sticker 3M or paint (should reflect vehicular lights during night) strips of yellow colour each of 75 mm width shall be provided on all sides.</td> </tr> <tr> <td>10</td> <td>Surface preparation for painting</td> <td>Sand blasting or 7 tank process followed by powder coating</td> </tr> </tbody> </table> <p>C. Lock:</p> <table border="1" data-bbox="422 1500 1468 1803"> <thead> <tr> <th>Sr. No.</th> <th>Parameter</th> <th>Requirement</th> </tr> </thead> <tbody> <tr> <td>1</td> <td>Arrangement</td> <td>3 types of lock arrangement: a) Padlock b) Sliding Bolt latch c) Door latch on inner side of door: Tower bolts shall be provided at top and bottom</td> </tr> <tr> <td>2</td> <td>Material of locking mechanism</td> <td>a) For Padlock: Same as that of enclosure b) Sliding Bolt latch of Aluminium c) For Door latch on inner side of door - Stainless Steel</td> </tr> </tbody> </table>	Sr. No.	Parameter	Requirement	1	Material of door	Cold Rolled Close Annealed (CRCA) sheet steel - powder coated.	2	Thickness	Thickness - 2.5 mm	3	Type of Door arrangement	The door shall be so fitted as to provide the interior with maximum protection from atmospheric conditions.	4	Insulation	For Mini pillar with Fuses front access Single door All doors shall be covered with min 1.5 mm thick SMC/FRP sheets.	5	Hinges	Minimum 3 Nos. anti-theft hinges for each door. Hinges shall not be visible from outside and should not be removable. Material of hinges and screws: Heavy duty stainless steel (SS) Hinges shall be of such construction that the doors can be swung open by not less than 120 deg.	6	Engraving	SLD shall be engraved & pasted on inside part of door	7	Gasket	The panel shall be provided with gasket all round the perimeter of covers, gland plates, removable covers and doors	8	Door handles	On front	9	Paint shade	International Orange shade No 592 of IS-5 with minimum 120 microns thickness. Good retention and UV & weather resistant paint. 2 Nos. retro reflective sticker 3M or paint (should reflect vehicular lights during night) strips of yellow colour each of 75 mm width shall be provided on all sides.	10	Surface preparation for painting	Sand blasting or 7 tank process followed by powder coating	Sr. No.	Parameter	Requirement	1	Arrangement	3 types of lock arrangement: a) Padlock b) Sliding Bolt latch c) Door latch on inner side of door: Tower bolts shall be provided at top and bottom	2	Material of locking mechanism	a) For Padlock: Same as that of enclosure b) Sliding Bolt latch of Aluminium c) For Door latch on inner side of door - Stainless Steel
Sr. No.	Parameter	Requirement																																										
1	Material of door	Cold Rolled Close Annealed (CRCA) sheet steel - powder coated.																																										
2	Thickness	Thickness - 2.5 mm																																										
3	Type of Door arrangement	The door shall be so fitted as to provide the interior with maximum protection from atmospheric conditions.																																										
4	Insulation	For Mini pillar with Fuses front access Single door All doors shall be covered with min 1.5 mm thick SMC/FRP sheets.																																										
5	Hinges	Minimum 3 Nos. anti-theft hinges for each door. Hinges shall not be visible from outside and should not be removable. Material of hinges and screws: Heavy duty stainless steel (SS) Hinges shall be of such construction that the doors can be swung open by not less than 120 deg.																																										
6	Engraving	SLD shall be engraved & pasted on inside part of door																																										
7	Gasket	The panel shall be provided with gasket all round the perimeter of covers, gland plates, removable covers and doors																																										
8	Door handles	On front																																										
9	Paint shade	International Orange shade No 592 of IS-5 with minimum 120 microns thickness. Good retention and UV & weather resistant paint. 2 Nos. retro reflective sticker 3M or paint (should reflect vehicular lights during night) strips of yellow colour each of 75 mm width shall be provided on all sides.																																										
10	Surface preparation for painting	Sand blasting or 7 tank process followed by powder coating																																										
Sr. No.	Parameter	Requirement																																										
1	Arrangement	3 types of lock arrangement: a) Padlock b) Sliding Bolt latch c) Door latch on inner side of door: Tower bolts shall be provided at top and bottom																																										
2	Material of locking mechanism	a) For Padlock: Same as that of enclosure b) Sliding Bolt latch of Aluminium c) For Door latch on inner side of door - Stainless Steel																																										

Rev No.	Description	Prepared By & Date	Checked By & Date	Approved for Issue By & Date
R00	TECHNICAL SPECIFICATION OF Mini Pillar with Fuses 415 V, 400 A	Yash M. Mane 	Ajay V. Potdar 	Ravindra M. Bhanage 
		22/12/2023	22/12/2023	22/12/2023

The Tata Power Company Ltd		TECHNICAL SPECIFICATION OF Mini Pillar with Fuses- 415V, 400A
ENSE-DS-2020-R00		Date of Issue: 22/12/2023

		<p>D. Apron:</p> <table border="1" data-bbox="421 300 1469 642"> <thead> <tr> <th>Sr. No.</th> <th>Parameter</th> <th>Requirement</th> </tr> </thead> <tbody> <tr> <td>1</td> <td>Material</td> <td>Cold rolled close annealed (CRCA) sheet steel</td> </tr> <tr> <td>2</td> <td>Design</td> <td>Apron shall be provide below the door level of Mini Pillar up to length of 270 mm on all 4 sides and easily removable such that exposed cables are not visible</td> </tr> <tr> <td>3</td> <td>Thickness</td> <td>3 mm minimum</td> </tr> <tr> <td>4</td> <td>Colour</td> <td>Black</td> </tr> </tbody> </table> <p>E. Cable Connection:</p> <table border="1" data-bbox="421 734 1469 999"> <thead> <tr> <th>Sr. No.</th> <th>Parameter</th> <th>Requirement</th> </tr> </thead> <tbody> <tr> <td>1</td> <td>Cable entry direction</td> <td>Cable entry shall be from bottom of Mini Pillar.</td> </tr> <tr> <td>2</td> <td>Cable termination clearance from gland plate.</td> <td>300 mm minimum</td> </tr> <tr> <td>3</td> <td>Cable termination</td> <td>All cable terminations shall be from the front side of the Mini Pillar only</td> </tr> </tbody> </table> <p>F. Bus- bars:</p> <table border="1" data-bbox="421 1090 1469 1850"> <thead> <tr> <th>Sr. No.</th> <th>Parameter</th> <th>Requirement</th> </tr> </thead> <tbody> <tr> <td>1</td> <td>Material grade</td> <td>Phase & Neutral bus-bars as per IS 5082 - Aluminium grade 19501 (H2).</td> </tr> <tr> <td>2</td> <td>Bus-bar colour coding for R, Y, B & Neutral</td> <td>Heat shrinkable insulation sleeves (1.1 kV voltage grade and min. Class A insulation class) of colour Red, Yellow, Blue and Black respectively.</td> </tr> <tr> <td>3</td> <td>Bus-bar size (in mm)</td> <td>1x50x10mm for Phase & Neutral (Al)</td> </tr> <tr> <td>4</td> <td>Bus-bar configuration</td> <td>Single bus-bars (per phase and neutral) shall be provided.</td> </tr> <tr> <td>5</td> <td>Bus-bar arrangement</td> <td>Horizontally placed, with R phase bus at top.</td> </tr> <tr> <td>6</td> <td>Bus-bar phase barriers/ Phase separators (R-Y & Y-B)</td> <td>FRP insulating sheet - (to be placed near to the phase bus-bar) (min 3 mm thickness) shall be provided between bus-bars, so as to ensure that there is no accidental contact with any live parts. (65 mm width)</td> </tr> <tr> <td>7</td> <td>Bus-bar support insulators</td> <td>2 nos per phase and neutral</td> </tr> <tr> <td rowspan="2">8</td> <td rowspan="2">Cable size</td> <td>Incoming</td> <td>Outgoing</td> </tr> <tr> <td>4C x 300 sq.mm.</td> <td>4C x 185 sq.mm.</td> </tr> </tbody> </table>	Sr. No.	Parameter	Requirement	1	Material	Cold rolled close annealed (CRCA) sheet steel	2	Design	Apron shall be provide below the door level of Mini Pillar up to length of 270 mm on all 4 sides and easily removable such that exposed cables are not visible	3	Thickness	3 mm minimum	4	Colour	Black	Sr. No.	Parameter	Requirement	1	Cable entry direction	Cable entry shall be from bottom of Mini Pillar.	2	Cable termination clearance from gland plate.	300 mm minimum	3	Cable termination	All cable terminations shall be from the front side of the Mini Pillar only	Sr. No.	Parameter	Requirement	1	Material grade	Phase & Neutral bus-bars as per IS 5082 - Aluminium grade 19501 (H2).	2	Bus-bar colour coding for R, Y, B & Neutral	Heat shrinkable insulation sleeves (1.1 kV voltage grade and min. Class A insulation class) of colour Red, Yellow, Blue and Black respectively.	3	Bus-bar size (in mm)	1x50x10mm for Phase & Neutral (Al)	4	Bus-bar configuration	Single bus-bars (per phase and neutral) shall be provided.	5	Bus-bar arrangement	Horizontally placed, with R phase bus at top.	6	Bus-bar phase barriers/ Phase separators (R-Y & Y-B)	FRP insulating sheet - (to be placed near to the phase bus-bar) (min 3 mm thickness) shall be provided between bus-bars, so as to ensure that there is no accidental contact with any live parts. (65 mm width)	7	Bus-bar support insulators	2 nos per phase and neutral	8	Cable size	Incoming	Outgoing	4C x 300 sq.mm.	4C x 185 sq.mm.
Sr. No.	Parameter	Requirement																																																									
1	Material	Cold rolled close annealed (CRCA) sheet steel																																																									
2	Design	Apron shall be provide below the door level of Mini Pillar up to length of 270 mm on all 4 sides and easily removable such that exposed cables are not visible																																																									
3	Thickness	3 mm minimum																																																									
4	Colour	Black																																																									
Sr. No.	Parameter	Requirement																																																									
1	Cable entry direction	Cable entry shall be from bottom of Mini Pillar.																																																									
2	Cable termination clearance from gland plate.	300 mm minimum																																																									
3	Cable termination	All cable terminations shall be from the front side of the Mini Pillar only																																																									
Sr. No.	Parameter	Requirement																																																									
1	Material grade	Phase & Neutral bus-bars as per IS 5082 - Aluminium grade 19501 (H2).																																																									
2	Bus-bar colour coding for R, Y, B & Neutral	Heat shrinkable insulation sleeves (1.1 kV voltage grade and min. Class A insulation class) of colour Red, Yellow, Blue and Black respectively.																																																									
3	Bus-bar size (in mm)	1x50x10mm for Phase & Neutral (Al)																																																									
4	Bus-bar configuration	Single bus-bars (per phase and neutral) shall be provided.																																																									
5	Bus-bar arrangement	Horizontally placed, with R phase bus at top.																																																									
6	Bus-bar phase barriers/ Phase separators (R-Y & Y-B)	FRP insulating sheet - (to be placed near to the phase bus-bar) (min 3 mm thickness) shall be provided between bus-bars, so as to ensure that there is no accidental contact with any live parts. (65 mm width)																																																									
7	Bus-bar support insulators	2 nos per phase and neutral																																																									
8	Cable size	Incoming	Outgoing																																																								
		4C x 300 sq.mm.	4C x 185 sq.mm.																																																								

Rev No.	Description	Prepared By & Date	Checked By & Date	Approved for Issue By & Date
R00	TECHNICAL SPECIFICATION OF Mini Pillar with Fuses 415 V, 400 A	Yash M. Mane 	Ajay V. Potdar 	Ravindra M. Bhanage 
		22/12/2023	22/12/2023	22/12/2023

G. Panel Configuration:



Sr. No.	Parameter	Requirement
1	No. of Incoming	1
2	No. of outgoing	4

H. Earthing:

Sr. No.	Parameter	Requirement
1	Earth studs	On both sides of panel bottom. Shall be provide with M10 galvanized steel nut bolts washers. The earthing studs shall be welded from inside the enclosure.
2	Earth bus-bar	To be provided at panel bottom. 50 x 6 mm GI. The earth bus-bar shall be internally connected to two separate earth terminals located outside (on both sides of enclosure). The earth bus-bar shall be located at sufficient height from the gland plate.
3	Flexible earth connection to doors	Flexible PVC Copper wire 1.5 sq.mm. with green colour insulation on all doors.
4	Body Earthing	All hinged doors, Covers, Gland Plates shall be connected to the earth terminal, with the help of green coloured braided copper conductors of adequate size
5	Neutral Earth link	Earth Bus and Neutral Bus to be shorted with 50 x 6 mm GI link.

I. Fuse and Fuse base:

Sr. No.	Parameter	Requirement
1	Type of HRC fuse	Knife type DIN HRC fuse with fuse links as per IEC 60269-1, with tinned copper contacts.
2	Fuse puller	It shall be possible to replace the fuses on live system without compromising on safety.
3	Fuse base current carrying part	Tin plated copper (with spring) as IS 191
4	Fuse base material	DMC
5	Fuse fixing with bus-bars	Bolted type connection
6	Fuse Base	Fuse base shall have adequate contact surface with the busbars provided to ensure that no local heating takes place. Outgoing 4 nos, 160 A, Type 1
7	Fuse Outlet Clearances	Clearance of minimum 100mm between each fuse outlet and 125mm between fuse outlet and body of panel to be maintained.

Rev No.	Description	Prepared By & Date	Checked By & Date	Approved for Issue By & Date
R00	TECHNICAL SPECIFICATION OF Mini Pillar with Fuses 415 V, 400 A	Yash M. Mane 	Ajay V. Potdar 	Ravindra M. Bhanage 
		22/12/2023	22/12/2023	22/12/2023

J. Danger Board / Branding:

Sr. No.	Parameter	Requirement
1	Danger Board	Danger boards shall be provided in local language also on the on front & rear cover with red background and with white letters.
2	Danger Marking	Front and rear side danger marking with skull and bones with mention of voltage level of 440V AC as per IS 2551.
3	Branding Plate	Separate metallic name plate with Tata Power Logo of Dimension 6*6 Inches as per Annexure 1

Reference GA DRAWING:

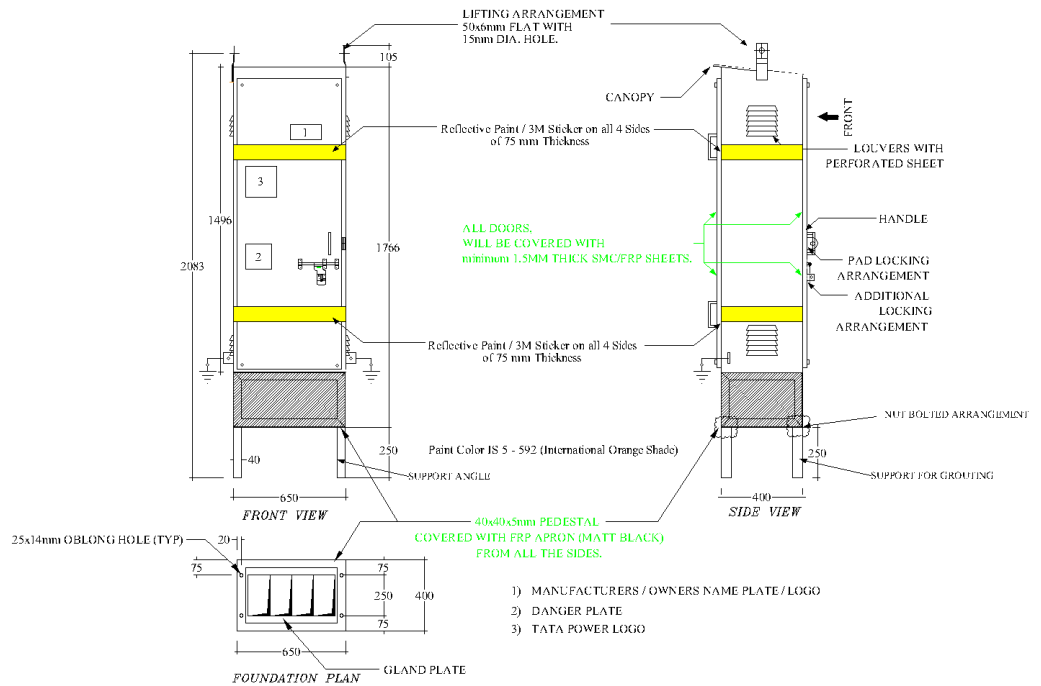

Rev No.	Description	Prepared By & Date	Checked By & Date	Approved for Issue By & Date
R00	TECHNICAL SPECIFICATION OF Mini Pillar with Fuses 415 V, 400 A	Yash M. Mane 	Ajay V. Potdar 	Ravindra M. Bhanage
		22/12/2023	22/12/2023	22/12/2023

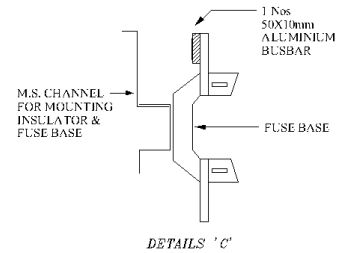
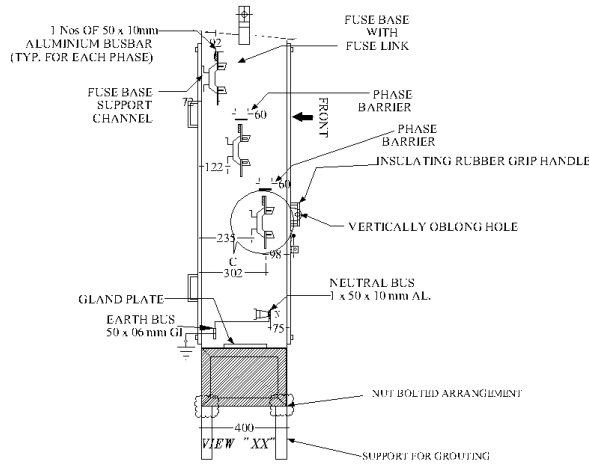
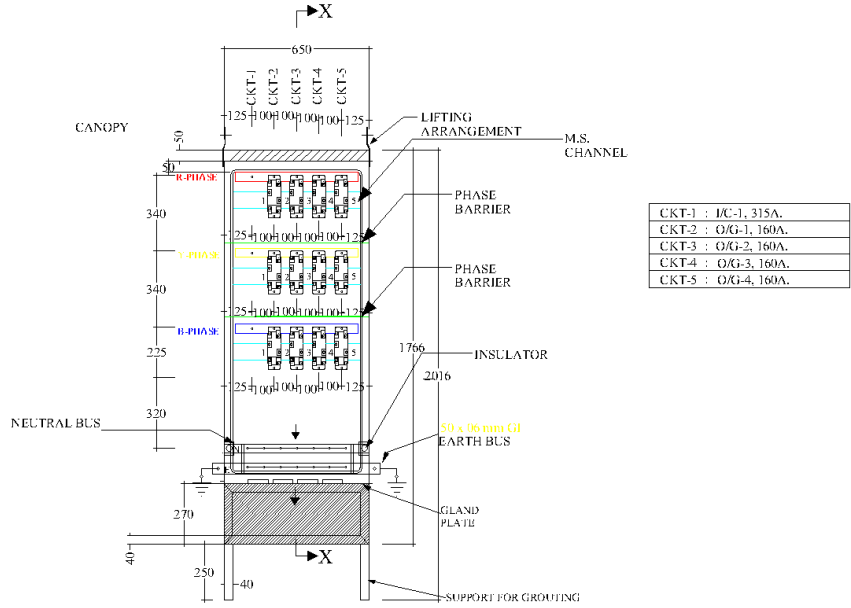

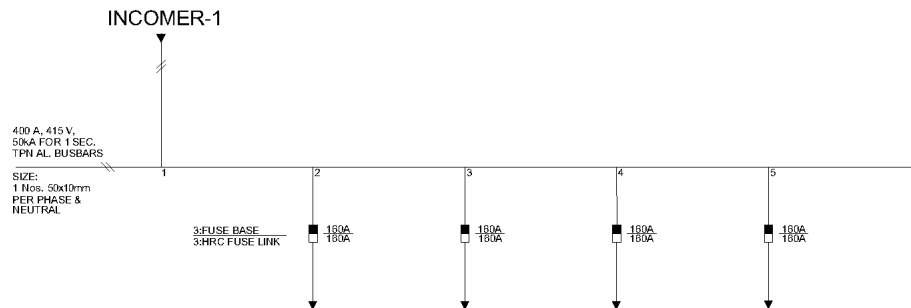

SLD:



Rev No.	Description	Prepared By & Date	Checked By & Date	Approved for Issue By & Date
R00	TECHNICAL SPECIFICATION OF Mini Pillar with Fuses 415 V, 400 A	Yash M. Mane 	Ajay V. Potdar 	Ravindra M. Bhanage
		22/12/2023	22/12/2023	22/12/2023



The Tata Power Company Ltd		TECHNICAL SPECIFICATION OF Mini Pillar with Fuses- 415V, 400A
ENSE-DS-2020-R00		Date of Issue: 22/12/2023

6.0	NAME PLATE & MARKINGS	<p>6.1 Name plate- On front door top left side-showing</p> <ol style="list-style-type: none"> 1) Purchaser name & PO number. 2) Manufacturer name 3) Month / year of manufacturing 4) 'Property of Tata Power' 5) Mini pillar serial number to be provided. 																								
7.0	TESTS	<p>All routine, acceptance & type tests shall be carried out in accordance with the relevant IS/IEC. Following tests shall be necessarily conducted on the 'Sub Feeder Pillar' in addition to others specified in IS/IEC standards.</p> <p>*In case of any conflict on any technical particular, the stricter requirement mentioned in the relevant standard shall be valid.</p>																								
7.1	TYPE TEST	<p>Type test - Only type tested components – Insulators & aluminium bus bar shall be accepted.</p> <p>For Enclosure with busbar</p> <table border="1" data-bbox="421 891 1453 1312"> <thead> <tr> <th>Sr. No.</th> <th>Test</th> <th>Clause No.</th> <th>Reference Standard</th> </tr> </thead> <tbody> <tr> <td style="text-align: center;">1</td> <td>Verification of temperature-rise limits</td> <td>Clause No 8.2</td> <td>IS 5039</td> </tr> <tr> <td style="text-align: center;">2</td> <td>Verification of dielectric properties</td> <td>Clause No 8.3</td> <td>IS 5039</td> </tr> <tr> <td style="text-align: center;">3</td> <td>Verification of short-circuits strength</td> <td>Clause No 8.4</td> <td>IS 5039</td> </tr> <tr> <td style="text-align: center;">4</td> <td>Verification of clearance and creepage distances</td> <td>Clause No 8.5</td> <td>IS 5039</td> </tr> <tr> <td style="text-align: center;">5</td> <td>Verification of degree of protection</td> <td>Clause No 8.6</td> <td>IS 5039</td> </tr> </tbody> </table>	Sr. No.	Test	Clause No.	Reference Standard	1	Verification of temperature-rise limits	Clause No 8.2	IS 5039	2	Verification of dielectric properties	Clause No 8.3	IS 5039	3	Verification of short-circuits strength	Clause No 8.4	IS 5039	4	Verification of clearance and creepage distances	Clause No 8.5	IS 5039	5	Verification of degree of protection	Clause No 8.6	IS 5039
Sr. No.	Test	Clause No.	Reference Standard																							
1	Verification of temperature-rise limits	Clause No 8.2	IS 5039																							
2	Verification of dielectric properties	Clause No 8.3	IS 5039																							
3	Verification of short-circuits strength	Clause No 8.4	IS 5039																							
4	Verification of clearance and creepage distances	Clause No 8.5	IS 5039																							
5	Verification of degree of protection	Clause No 8.6	IS 5039																							
7.2	ROUTINE TEST	<ol style="list-style-type: none"> 1. Visual inspection & dimensional check 2. Insulation Resistance test 3. HV Test 																								
7.3	ACCEPTANCE TEST	<ol style="list-style-type: none"> 1) Verification of clearance and creepage distance 2) Paint thickness check 3) Paint Shade 4) Wiring checks 5) Insulation resistance test 6) 1 unit from 1st lot shall be tested for Temperature rise test along with fuses. (Bidder to arrange for the same) 7) HV Test 8) Visual inspection & dimensional check 																								

Rev No.	Description	Prepared By & Date	Checked By & Date	Approved for Issue By & Date
R00	TECHNICAL SPECIFICATION OF Mini Pillar with Fuses 415 V, 400 A	Yash M. Mane  22/12/2023	Ajay V. Potdar  22/12/2023	Ravindra M. Bhanage  22/12/2023



The Tata Power Company Ltd		TECHNICAL SPECIFICATION OF Mini Pillar with Fuses- 415V, 400A
ENSE-DS-2020-R00		Date of Issue: 22/12/2023

8.0	TYPE TEST CERTIFICATES	<p>Bidder shall furnish the type test report of 'Mini Pillar of same design' for the tests as mentioned in Clause no.7 of this specification as per reference standards. Complete set of Type Tests shall be conducted at CPRI/ERDA/NABL accredited laboratory. Type test should have been conducted in certified test laboratories during the period not exceeding 10 years from the date of opening the bid. any test report not acceptable or any/all type tests (including additional type tests, if any) not carried out, same shall be carried out without any cost implication to TATA POWER COMPANY.</p> <p>Type tests shall have been conducted in certified Test laboratories during the period not exceeding 10 years from the date of opening the bid. In case if type test conducted beyond 10 years then bidder to certify on letter head of parent OEM that no design change & no manufacturing plant change occurred from type tested product.</p> <p>In the event of any discrepancy in the test reports, i.e. any test report not acceptable or any/all type tests (including additional type tests, if any) not carried out, same shall be carried out without any cost implication to TATA POWER.</p> <p>Bidders shall submit Type Test Undertaking for conducting & submit report with 60 days of Outline Agreement.</p>
9.0	PRE- DESPATCH INSPECTION	<p>The Material shall be subject to inspection by a duly authorized representative of the TATA POWER COMPANY. Inspection may be made at any stage of manufacture at the discretion of the Purchaser and the equipment, if found unsatisfactory as to workmanship or material, the same is liable to rejection. Bidder shall always grant free access to the places of manufacture to TATA POWER COMPANY `s representatives when the work is in progress. Inspection by the TATA POWER COMPANY or its authorized representatives shall not relieve the Bidder of his obligation of furnishing equipment in accordance with the specifications. TATA POWER COMPANY authorized representatives shall have the right to inspect the design, materials and workmanship and to report thereon, at any stage of manufacture, if found necessary. All facilities shall be extended to our representatives for witnessing the tests. Due notice shall be given to us to enable us to depute our representatives for stage inspection.</p> <p>Material shall be dispatched after specific MDCC (Material Dispatch Clearance Certificate) is issued by TATA POWER COMPANY. Five certified copies of all test certificates including type tests, sample test certificates shall be sent to us for our approval prior to dispatch of materials.</p> <p>Following documents shall be sent along with material</p> <ol style="list-style-type: none"> a) Test reports b) MDCC issued by TATA POWER COMPANY c) Invoice in duplicate d) Packing list e) Drawings & catalogue f) Delivery Challan g) Other Documents (as applicable)

Rev No.	Description	Prepared By & Date	Checked By & Date	Approved for Issue By & Date
R00	TECHNICAL SPECIFICATION OF Mini Pillar with Fuses 415 V, 400 A	Yash M. Mane 	Ajay V. Potdar 	Ravindra M. Bhanage 
		22/12/2023	22/12/2023	22/12/2023



The Tata Power Company Ltd		TECHNICAL SPECIFICATION OF Mini Pillar with Fuses- 415V, 400A
ENSE-DS-2020-R00		Date of Issue: 22/12/2023

10.	INSPECTION AFTER RECEIPT AT STORES	<p>The material received at TATA POWER Store will be inspected for acceptance and shall be liable for rejection if found different from the reports of the pre-dispatch inspection and one copy of the report shall be sent to TATA POWER COMPANY.</p> <p>If any deviation or anomaly observed at this stage same need to be rectified by bidder at bidders own cost at earliest.</p> <p>The delay in rectification shall lead to any contractual penalty.</p>
11.0	GUARANTEE	<p>Bidder shall stand guarantee towards design, materials, workmanship & quality of process / manufacturing of items under this contract for due and intended performance of the same, as an integrated product delivered under this contract. In the event any defect is found by the Purchaser up to a period of at least 12 months from the date of commissioning or 24 months from the date of last supplies made under the contract whichever is earlier, Bidder shall be liable to undertake to replace/rectify such defects at its own costs, within mutually agreed time frame, and to the entire satisfaction of the Purchaser, failing which the Purchaser will be at liberty to get it replaced/rectified at Bidder's risks and costs and recover all such expenses plus the Purchaser's own charges (@ 20% of expenses incurred), from the Bidder or from the " Security cum Performance Deposit" as the case may be.</p> <p>In case of GP failure, BA shall report at site within 48 hours from intimation and arrange for rectification of fault within a mutually agreed time. In case rectification at site is not possible then alternative arrangement (replacement) to be made by BA within 15 days of intimation of failure.</p> <p>Bidder shall further be responsible for 'free replacement' for another period of THREE years from the end of the guarantee period for any 'Latent Defects' if noticed and reported by the Purchaser.</p>
12.0	PACKING AND TRANSPORT	<p>Bidder shall ensure that the item covered under this specification shall be packaged for rail/road transport in a manner so as to protect the equipment from damage in transit.</p> <p>The material used for packing shall be environmentally friendly.</p> <p>Packing identification labels- To show purchaser name, PO number, quantity of panels, Panel type, Manufacturer serial number.</p> <p>Handling instruction- To be marked on packing boxes.</p> <p>No single use plastic to be used in packing material. Packing should be done with environment friendly recyclable materials.</p>
13.0	TENDER SAMPLE	Not applicable.

Rev No.	Description	Prepared By & Date	Checked By & Date	Approved for Issue By & Date
R00	TECHNICAL SPECIFICATION OF Mini Pillar with Fuses 415 V, 400 A	Yash M. Mane 	Ajay V. Potdar 	Ravindra M. Bhanage 
		22/12/2023	22/12/2023	22/12/2023



The Tata Power Company Ltd		TECHNICAL SPECIFICATION OF Mini Pillar with Fuses- 415V, 400A
ENSE-DS-2020-R00		Date of Issue: 22/12/2023

14.0	QUALITY CONTROL	<p>The Bidder shall submit with the offer Quality assurance plan indicating the various stages of inspection, the tests and checks which will be carried out on the material of construction, components during manufacture and bought out items and fully assembled component and equipment after finishing. As part of the plan, a schedule for stage and final inspection within the parameters of the delivery schedule shall be furnished.</p> <p>TATA POWER COMPANY shall reserve the sole rights for the type test of a random sample from the lot and in case of any discrepancy or deviation from the Type test certificates submitted along with the Bid; the complete Lot shall be rejected.</p> <p>TATA POWER COMPANY representative or its nominated representative shall have free access to the Bidder's works to carry out inspections.</p> <p>If anything missing in QAP and required as per other clauses of this document, bidder is liable to perform the same without cost implication.</p>
15.0	MINIMUM TESTING FACILITIES	<p>Bidder shall have adequate in-house testing facilities for carrying out all routine tests & acceptance tests as per relevant International / Indian standards</p>
16.0	MANUFACTURING ACTIVITIES	<p>The successful bidder will have to submit first GTP & Drawing with 7 days from placement of outline agreement for approval and complete the approval process within 14 days of outline agreement. The date of Code -2/ Code-1 approval given by TATA Power will be treated as first day for assessment of LD (if applicable).</p>
17.0	SPARES, ACCESSORIES AND TOOLS	<p>Keys of door, 1 set of Fuse Puller with every 30 units.</p>
18.0	DRAWINGS AND DOCUMENTS	<p>Following drawings and documents shall be prepared based on TATA POWER COMPANY specifications and statutory requirements and shall be submitted with the bid.</p> <ul style="list-style-type: none"> a) Completely filled in Technical Particulars b) General description of the equipment and all components including brochures. c) General arrangement drawing. d) Bill of material e) Experience List f) Type test certificates g) Any other technical document, if required <p>All the documents & drawings shall be in English language</p>

Rev No.	Description	Prepared By & Date	Checked By & Date	Approved for Issue By & Date
R00	TECHNICAL SPECIFICATION OF Mini Pillar with Fuses 415 V, 400 A	Yash M. Mane  22/12/2023	Ajay V. Potdar  22/12/2023	Ravindra M. Bhanage  22/12/2023

The Tata Power Company Ltd		TECHNICAL SPECIFICATION OF Mini Pillar with Fuses- 415V, 400A
ENSE-DS-2020-R00		Date of Issue: 22/12/2023

19	SCHEDULE "A" GUARANTEED TECHNICAL PARTICULARS:	Clause wise compliance of this specification is to be submitted with bid documents.						
20.0	SCHEDULE "B" DEVIATIONS	<p style="text-align: center;"><u>(TO BE ENCLOSED WITH TECHNICAL BID)</u></p> <p>All deviations from this specification shall be set out by the Bidders, clause by Clause in this schedule. Unless specifically mentioned in this Schedule, the tender shall be deemed to confirm the purchaser's specifications:</p> <table border="1" data-bbox="421 647 1490 1386" style="width: 100%; border-collapse: collapse;"> <thead> <tr> <th data-bbox="421 647 708 770" style="width: 33%;">S.No.</th> <th data-bbox="708 647 1018 770" style="width: 33%;">Clause No.</th> <th data-bbox="1018 647 1490 770" style="width: 34%;">Details of deviation with justifications</th> </tr> </thead> <tbody> <tr> <td style="height: 250px;"></td> <td></td> <td></td> </tr> </tbody> </table> <p>We confirm that there are no deviations apart from those detailed above.</p> <p>Seal of the Company:</p> <p>Designation</p> <p>Signature</p>	S.No.	Clause No.	Details of deviation with justifications			
S.No.	Clause No.	Details of deviation with justifications						

Rev No.	Description	Prepared By & Date	Checked By & Date	Approved for Issue By & Date
R00	TECHNICAL SPECIFICATION OF Mini Pillar with Fuses 415 V, 400 A	Yash M. Mane  22/12/2023	Ajay V. Potdar  22/12/2023	Ravindra M. Bhanage  22/12/2023

The Tata Power Company Ltd		TECHNICAL SPECIFICATION OF Mini Pillar with Fuses- 415V, 400A
ENSE-DS-2020-R00		Date of Issue: 22/12/2023

Annexure – I

Tata power Branding Name plate -

Separate metallic name plate with Tata Power Logo of Dimension 6*6 Inches in clear font as shown below.

Relationship between the two marks- size

The Tata and Tata Power Marks are always used in conjunction with each other, never appearing in isolation on Tata Power communication.

The height of the letter T of Tata (T-height) is the basic measure for all sizes and proportions.

The rounded measure 2T in height, is separated from the Tata lettering by a distance of 1/2T.

The T height of both, the Tata and the Tata Power Marks is to be the same, except in exceptional cases on approval from the Corporate Communications team.







Relationship between the two marks- positioning

The two marks can appear stacked, which is the preferred placement, or linear, by the side of one another.

Centre aligned - Stacked (Preferred)





Rev No.	Description	Prepared By & Date	Checked By & Date	Approved for Issue By & Date
R00	TECHNICAL SPECIFICATION OF Mini Pillar with Fuses 415 V, 400 A	Yash M. Mane  22/12/2023	Ajay V. Potdar  22/12/2023	Ravindra M. Bhanage  22/12/2023

The Tata Power Company Ltd		TECHNICAL SPECIFICATION OF Mini Pillar with Fuses- 415V, 400A
ENSE-DS-2020-R00		Date of Issue: 22/12/2023

Annexure 2: Inspection Testing Plan

- 1) Verification of clearance and creepage distance
- 2) Paint thickness check
- 3) Paint Shade
- 4) Wiring checks
- 5) Insulation resistance test
- 6) 1 unit from 1st lot shall be tested for Temperature rise test with fuses. (Bidder to arrange for the same)
- 7) HV Test
- 8) Visual inspection & dimensional check

Rev No.	Description	Prepared By & Date	Checked By & Date	Approved for Issue By & Date
R00	TECHNICAL SPECIFICATION OF Mini Pillar with Fuses 415 V, 400 A	Yash M. Mane  22/12/2023	Ajay V. Potdar  22/12/2023	Ravindra M. Bhanage  22/12/2023

TECHNICAL SPECIFICATION

Mini Pillar without Fuses- 415 V, 400A



*The Tata Power Company Ltd.
Engineering Services (ENSE),
Distribution Division,
Senapati Bapat Marg,
Lower Parel,
Mumbai – 400013
Maharashtra*



The Tata Power Company Ltd		TECHNICAL SPECIFICATION OF Mini Pillar without Fuses- 415V, 400A
ENSE-DS-2021-R00		Date of Issue: 22/12/2023

TECHNICAL SPECIFICATION COVER SHEET

Document No: ENSE-DS-2021-R00

Document Title: Technical Specification of Mini Pillar without Fuses 415V, 400A

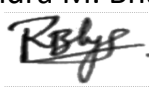

R00	ENSE-DS-2021-R00 For tendering Purpose	22/12/2023	YMM		AVP		RMB	
R1	SPEC-NET- Mini Pillar-01	10/11/2016	ND	-sd-	SK	-sd-	CC	-sd-
R0	SPEC-NET- Mini Pillar-00	30/05/2013	AP	-sd-	AP	-sd-	CC	-sd-
Rev No.	Remarks	Date	Initials	Sign	Initials	Sign	Initials	Sign
			Prepared By		Reviewed By		Approved & Issued By	

Rev No.	Description	Prepared By & Date	Checked By & Date	Approved for Issue By & Date
R00	TECHNICAL SPECIFICATION OF Mini Pillar without Fuses 415 V, 400 A	Yash M. Mane  22/12/2023	Ajay V. Potdar  22/12/2023	Ravindra M. Bhanage  22/12/2023

The Tata Power Company Ltd		TECHNICAL SPECIFICATION OF Mini Pillar without Fuses- 415V, 400A
ENSE-DS-2021-R00		Date of Issue: 22/12/2023



CONTENTS

- 1.0 SCOPE
 - 2.0 APPLICABLE STANDARDS
 - 3.0 CLIMATIC CONDITIONS OF THE INSTALLATION
 - 4.0 GENERAL TECHNICAL REQUIREMENTS
 - 5.0 GENERAL CONSTRUCTIONS
 - 6.0 NAME PLATE & MARKINGS
 - 7.0 TESTS
 - 8.0 TYPE TEST CERIFICATES
 - 9.0 PRE-DISPATCH INSPECTION
 - 10.0 INSPECTION AFTER RECEIPT AT STORE
 - 11.0 GUARANTEE
 - 12.0 PACKING AND TRANSPORT
 - 13.0 TENDER SAMPLE
 - 14.0 QUALITY CONTROL
 - 15.0 MINIMUM TESTING FACILITIES
 - 16.0 MANUFACTURING ACTIVITIES
 - 17.0 SPARES, ACCESSORIES AND TOOLS
 - 18.0 DRAWING AND DOCUMENTS
 - 19.0 SCHEDULE "A" GUARANTEED TECHNICAL PARTICULARS
 - 20.0 SCHEDULE "B" DEVIATIONS
- + ANNEXURE 1 & 2

Rev No.	Description	Prepared By & Date	Checked By & Date	Approved for Issue By & Date
R00	TECHNICAL SPECIFICATION OF Mini Pillar without Fuses 415 V, 400 A	Yash M. Mane 	Ajay V. Potdar 	Ravindra M. Bhanage 
		22/12/2023	22/12/2023	22/12/2023



The Tata Power Company Ltd		TECHNICAL SPECIFICATION OF Mini Pillar without Fuses- 415V, 400A
ENSE-DS-2021-R00		Date of Issue: 22/12/2023

1.0	SCOPE	<p>This specification covers design, engineering, manufacture; shop testing, inspection, painting, packing, and supply of 415V Mini Pillar complete with all accessories for efficient and trouble-free operation of the distribution network for Tata Power Company Ltd. at Mumbai.</p> <p>It is not our intent to specify completely herein all details of design and construction of the equipment. However, the equipment shall conform in all respects to high standards of Engineering design and workmanship and shall be capable of performing in a manner acceptable to the Purchaser (Tata Power Company) who will interpret the meaning of drawings and specification and shall be entitled to reject any work or material which in his judgement is not in full accordance therewith.</p> <p>All the bought-out items shall be of reputed make and shall be subject to approval by the Purchaser (Tata Power Company) after award of contract. All Sub vendor/Subcontractor list shall also be subject to approval by the Purchaser (Tata Power Company) after award of contract.</p>																				
2.0	APPLICABLE STANDARDS	<p>The equipment (and the materials used) covered by this specification shall unless otherwise stated, be designed, manufactured and tested in accordance with the latest editions of the following Indian, IEC / International standards , with latest amendment from time to time, thereof, some of which are listed below:</p> <p>The Sub Feeder Pillar shall comply with the requirements stated in the latest editions of the following recommendations, standard and specifications:</p> <table border="1"> <thead> <tr> <th>INDIAN STANDARDS (IS)</th> <th>Title</th> </tr> </thead> <tbody> <tr> <td>IS 5039</td> <td>Specification for distribution pillars below 1000V AC</td> </tr> <tr> <td>IS 5</td> <td>Colour of ready mixed paints and enamels</td> </tr> <tr> <td>IS 191</td> <td>Copper Specification</td> </tr> <tr> <td>IS 5082</td> <td>Wrought aluminium and aluminium alloy bars, rods, tubes, sections, plates and sheets for electrical applications</td> </tr> <tr> <td>IS 1359</td> <td>Electroplated Coatings of Tin</td> </tr> <tr> <td>IS 1730</td> <td>Dimensions for steel plates, sheets strips and flats for general engineering purposes</td> </tr> <tr> <td>IS 2551</td> <td>Danger Notice plates</td> </tr> <tr> <td>IS 4759</td> <td>Hot-dip Zinc coatings on structural steel and other allied products</td> </tr> <tr> <td>IS 14772</td> <td>General requirements for enclosures for accessories for household and similar fixed electrical installations</td> </tr> </tbody> </table>	INDIAN STANDARDS (IS)	Title	IS 5039	Specification for distribution pillars below 1000V AC	IS 5	Colour of ready mixed paints and enamels	IS 191	Copper Specification	IS 5082	Wrought aluminium and aluminium alloy bars, rods, tubes, sections, plates and sheets for electrical applications	IS 1359	Electroplated Coatings of Tin	IS 1730	Dimensions for steel plates, sheets strips and flats for general engineering purposes	IS 2551	Danger Notice plates	IS 4759	Hot-dip Zinc coatings on structural steel and other allied products	IS 14772	General requirements for enclosures for accessories for household and similar fixed electrical installations
INDIAN STANDARDS (IS)	Title																					
IS 5039	Specification for distribution pillars below 1000V AC																					
IS 5	Colour of ready mixed paints and enamels																					
IS 191	Copper Specification																					
IS 5082	Wrought aluminium and aluminium alloy bars, rods, tubes, sections, plates and sheets for electrical applications																					
IS 1359	Electroplated Coatings of Tin																					
IS 1730	Dimensions for steel plates, sheets strips and flats for general engineering purposes																					
IS 2551	Danger Notice plates																					
IS 4759	Hot-dip Zinc coatings on structural steel and other allied products																					
IS 14772	General requirements for enclosures for accessories for household and similar fixed electrical installations																					

Rev No.	Description	Prepared By & Date	Checked By & Date	Approved for Issue By & Date
R00	TECHNICAL SPECIFICATION OF Mini Pillar without Fuses 415 V, 400 A	Yash M. Mane 	Ajay V. Potdar 	Ravindra M. Bhanage 
		22/12/2023	22/12/2023	22/12/2023

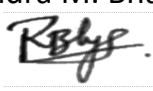

The Tata Power Company Ltd		TECHNICAL SPECIFICATION OF Mini Pillar without Fuses- 415V, 400A
ENSE-DS-2021-R00		Date of Issue: 22/12/2023

		<table border="1"> <thead> <tr> <th>IEC STANDARDS</th> <th>Title</th> </tr> </thead> <tbody> <tr> <td>IEC TR 61439-0</td> <td>Low-voltage switchgear and controlgear assemblies- Part 0: Guidance to specifying assemblies</td> </tr> <tr> <td>IEC 60947-3</td> <td>Low-voltage switchgear and controlgear - Part 3: Switches, disconnectors, switch-disconnectors and fuse-combination units.</td> </tr> <tr> <td>IEC 60947-1</td> <td>Low-voltage switchgear and controlgear - Part 1: General rules</td> </tr> <tr> <td>IEC 61439-2</td> <td>Low-voltage switchgear and controlgear assemblies - Part 2: Power switchgear and controlgear assemblies</td> </tr> <tr> <td>IEC 60664</td> <td>Insulation coordination for equipment within low-voltage systems - ALL PARTS</td> </tr> <tr> <td>IEC 61439-2</td> <td>Low-voltage switchgear and controlgear assemblies Part 2: Power switchgear and controlgear assemblies</td> </tr> <tr> <td>IEC 60529</td> <td>Degrees of protection provided by enclosures (IP Code)</td> </tr> </tbody> </table> <p>In case of any conflict on any technical particular in the specification, the stricter requirement mentioned in the relevant standard shall be valid.</p>	IEC STANDARDS	Title	IEC TR 61439-0	Low-voltage switchgear and controlgear assemblies- Part 0: Guidance to specifying assemblies	IEC 60947-3	Low-voltage switchgear and controlgear - Part 3: Switches, disconnectors, switch-disconnectors and fuse-combination units.	IEC 60947-1	Low-voltage switchgear and controlgear - Part 1: General rules	IEC 61439-2	Low-voltage switchgear and controlgear assemblies - Part 2: Power switchgear and controlgear assemblies	IEC 60664	Insulation coordination for equipment within low-voltage systems - ALL PARTS	IEC 61439-2	Low-voltage switchgear and controlgear assemblies Part 2: Power switchgear and controlgear assemblies	IEC 60529	Degrees of protection provided by enclosures (IP Code)																
		IEC STANDARDS	Title																															
IEC TR 61439-0	Low-voltage switchgear and controlgear assemblies- Part 0: Guidance to specifying assemblies																																	
IEC 60947-3	Low-voltage switchgear and controlgear - Part 3: Switches, disconnectors, switch-disconnectors and fuse-combination units.																																	
IEC 60947-1	Low-voltage switchgear and controlgear - Part 1: General rules																																	
IEC 61439-2	Low-voltage switchgear and controlgear assemblies - Part 2: Power switchgear and controlgear assemblies																																	
IEC 60664	Insulation coordination for equipment within low-voltage systems - ALL PARTS																																	
IEC 61439-2	Low-voltage switchgear and controlgear assemblies Part 2: Power switchgear and controlgear assemblies																																	
IEC 60529	Degrees of protection provided by enclosures (IP Code)																																	
3.0	<p>CLIMATIC CONDITIONS OF THE INSTALLATION</p> <table border="1"> <tbody> <tr> <td>1</td> <td>Maximum ambient temperature</td> <td>43 deg.C</td> </tr> <tr> <td>2</td> <td>Max. Daily average ambient temp</td> <td>35 deg.C</td> </tr> <tr> <td>3</td> <td>Min Ambient Temperature</td> <td>07 deg.C</td> </tr> <tr> <td>4</td> <td>Maximum Relative Humidity</td> <td>100%</td> </tr> <tr> <td>5</td> <td>Minimum Relative Humidity</td> <td>40%</td> </tr> <tr> <td>6</td> <td>Average No. of thunderstorm per annum</td> <td>50</td> </tr> <tr> <td>7</td> <td>Average Annual Rainfall</td> <td>2380mm</td> </tr> <tr> <td>8</td> <td>Average No. of rainy days per annum</td> <td>115</td> </tr> <tr> <td>9</td> <td>Rainy months</td> <td>June to Oct.</td> </tr> <tr> <td>10</td> <td>Altitude above MSL not exceeding</td> <td>300 meters</td> </tr> <tr> <td>11</td> <td>Average Air Pressure</td> <td>29.6-inch Hg</td> </tr> </tbody> </table> <p>Atmosphere is generally laden with mild acid and dust suspended during summer months and subjected to fog in winter months. The design of the equipment and accessories shall be suitable to withstand seismic forces corresponding to an acceleration of 0.1g.</p>	1	Maximum ambient temperature	43 deg.C	2	Max. Daily average ambient temp	35 deg.C	3	Min Ambient Temperature	07 deg.C	4	Maximum Relative Humidity	100%	5	Minimum Relative Humidity	40%	6	Average No. of thunderstorm per annum	50	7	Average Annual Rainfall	2380mm	8	Average No. of rainy days per annum	115	9	Rainy months	June to Oct.	10	Altitude above MSL not exceeding	300 meters	11	Average Air Pressure	29.6-inch Hg
1	Maximum ambient temperature	43 deg.C																																
2	Max. Daily average ambient temp	35 deg.C																																
3	Min Ambient Temperature	07 deg.C																																
4	Maximum Relative Humidity	100%																																
5	Minimum Relative Humidity	40%																																
6	Average No. of thunderstorm per annum	50																																
7	Average Annual Rainfall	2380mm																																
8	Average No. of rainy days per annum	115																																
9	Rainy months	June to Oct.																																
10	Altitude above MSL not exceeding	300 meters																																
11	Average Air Pressure	29.6-inch Hg																																

Rev No.	Description	Prepared By & Date	Checked By & Date	Approved for Issue By & Date
R00	TECHNICAL SPECIFICATION OF Mini Pillar without Fuses 415 V, 400 A	Yash M. Mane 	Ajay V. Potdar 	Ravindra M. Bhanage 
		22/12/2023	22/12/2023	22/12/2023

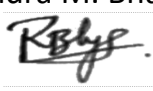

The Tata Power Company Ltd		TECHNICAL SPECIFICATION OF Mini Pillar without Fuses- 415V, 400A
ENSE-DS-2021-R00		Date of Issue: 22/12/2023

4.0	GENERAL TECHNICAL REQUIREMENTS	<table border="1"> <thead> <tr> <th>Sr. No</th> <th>Item Description</th> <th>Tata Power Requirement</th> </tr> </thead> <tbody> <tr> <td rowspan="3">1</td> <td rowspan="3">Manufacturer</td> <td>Name</td> </tr> <tr> <td>Manufacturer Address</td> </tr> <tr> <td>Contact telephone no</td> </tr> <tr> <td>2</td> <td>Main bus bar rating</td> <td>500A</td> </tr> <tr> <td rowspan="2">3</td> <td>No of incoming feeders</td> <td>Quantity-1Nos</td> </tr> <tr> <td>Incomer Rating</td> <td>Rating in Amp- 315A</td> </tr> <tr> <td rowspan="2">4</td> <td>No of outgoing feeders</td> <td>Quantity-04nos</td> </tr> <tr> <td>Outgoing Rating</td> <td>Rating in Amp- 160A</td> </tr> <tr> <td>5</td> <td>Panel construction</td> <td>CRCA sheet steel</td> </tr> <tr> <td>6</td> <td>Panel enclosure class</td> <td>IP54 - ingress protection (for outdoor installation)</td> </tr> <tr> <td>7</td> <td>Sheet steel thickness</td> <td>3 mm minimum for covers & canopy, 2.5 mm for doors(As per IS 5039)</td> </tr> <tr> <td>8</td> <td>Pedestal for mini pillar</td> <td>Of height 270 mm with side covers of MS painted in black</td> </tr> <tr> <td>9</td> <td>Door type for front & rear access</td> <td>Single door for mini pillar</td> </tr> <tr> <td>10</td> <td>Door hinges</td> <td>Three anti theft type hinges</td> </tr> <tr> <td>11</td> <td>Padlocking facility</td> <td>As per Specification</td> </tr> <tr> <td rowspan="2">12</td> <td rowspan="2">Master key for all doors</td> <td>Identical for all panels,</td> </tr> <tr> <td>1 no./ panel</td> </tr> <tr> <td>13</td> <td>External steel hardware</td> <td>Galvanized nut & bolts, yellow zinc plated 8.8 Grade for Electrical Contacts. Other Hardware grade 4.6</td> </tr> <tr> <td>14</td> <td>Phase & neutral Bus bar</td> <td>Aluminium grade 19501 (H2) as per IS 5082</td> </tr> <tr> <td>15</td> <td>Bus bar color coding for R,Y, B & neutral</td> <td>Heat shrinkable sleeves with color Red, Yellow, Blue & Black respectively</td> </tr> <tr> <td>16</td> <td>Bus bar size in mm</td> <td>1x50x10mm for Phase & Neutral (Al)</td> </tr> <tr> <td>17</td> <td>Earth bus size</td> <td>50x6mm GI</td> </tr> <tr> <td>18</td> <td>Main bus bar short circuit withstand capacity</td> <td>Above 50kA for 1 sec as per IEC 61439</td> </tr> <tr> <td>19</td> <td>Main bus bar maximum temperature rise</td> <td>Busbar: 45 deg C Terminals: 65 deg C</td> </tr> <tr> <td>20</td> <td>Bus bar support insulators</td> <td>As per IS13410 SMC / DMC, 1100V grade</td> </tr> </tbody> </table>	Sr. No	Item Description	Tata Power Requirement	1	Manufacturer	Name	Manufacturer Address	Contact telephone no	2	Main bus bar rating	500A	3	No of incoming feeders	Quantity-1Nos	Incomer Rating	Rating in Amp- 315A	4	No of outgoing feeders	Quantity-04nos	Outgoing Rating	Rating in Amp- 160A	5	Panel construction	CRCA sheet steel	6	Panel enclosure class	IP54 - ingress protection (for outdoor installation)	7	Sheet steel thickness	3 mm minimum for covers & canopy, 2.5 mm for doors(As per IS 5039)	8	Pedestal for mini pillar	Of height 270 mm with side covers of MS painted in black	9	Door type for front & rear access	Single door for mini pillar	10	Door hinges	Three anti theft type hinges	11	Padlocking facility	As per Specification	12	Master key for all doors	Identical for all panels,	1 no./ panel	13	External steel hardware	Galvanized nut & bolts, yellow zinc plated 8.8 Grade for Electrical Contacts. Other Hardware grade 4.6	14	Phase & neutral Bus bar	Aluminium grade 19501 (H2) as per IS 5082	15	Bus bar color coding for R,Y, B & neutral	Heat shrinkable sleeves with color Red, Yellow, Blue & Black respectively	16	Bus bar size in mm	1x50x10mm for Phase & Neutral (Al)	17	Earth bus size	50x6mm GI	18	Main bus bar short circuit withstand capacity	Above 50kA for 1 sec as per IEC 61439	19	Main bus bar maximum temperature rise	Busbar: 45 deg C Terminals: 65 deg C	20	Bus bar support insulators	As per IS13410 SMC / DMC, 1100V grade
		Sr. No	Item Description	Tata Power Requirement																																																																				
		1	Manufacturer	Name																																																																				
				Manufacturer Address																																																																				
				Contact telephone no																																																																				
		2	Main bus bar rating	500A																																																																				
		3	No of incoming feeders	Quantity-1Nos																																																																				
			Incomer Rating	Rating in Amp- 315A																																																																				
		4	No of outgoing feeders	Quantity-04nos																																																																				
			Outgoing Rating	Rating in Amp- 160A																																																																				
		5	Panel construction	CRCA sheet steel																																																																				
		6	Panel enclosure class	IP54 - ingress protection (for outdoor installation)																																																																				
		7	Sheet steel thickness	3 mm minimum for covers & canopy, 2.5 mm for doors(As per IS 5039)																																																																				
		8	Pedestal for mini pillar	Of height 270 mm with side covers of MS painted in black																																																																				
		9	Door type for front & rear access	Single door for mini pillar																																																																				
		10	Door hinges	Three anti theft type hinges																																																																				
		11	Padlocking facility	As per Specification																																																																				
		12	Master key for all doors	Identical for all panels,																																																																				
				1 no./ panel																																																																				
		13	External steel hardware	Galvanized nut & bolts, yellow zinc plated 8.8 Grade for Electrical Contacts. Other Hardware grade 4.6																																																																				
14	Phase & neutral Bus bar	Aluminium grade 19501 (H2) as per IS 5082																																																																						
15	Bus bar color coding for R,Y, B & neutral	Heat shrinkable sleeves with color Red, Yellow, Blue & Black respectively																																																																						
16	Bus bar size in mm	1x50x10mm for Phase & Neutral (Al)																																																																						
17	Earth bus size	50x6mm GI																																																																						
18	Main bus bar short circuit withstand capacity	Above 50kA for 1 sec as per IEC 61439																																																																						
19	Main bus bar maximum temperature rise	Busbar: 45 deg C Terminals: 65 deg C																																																																						
20	Bus bar support insulators	As per IS13410 SMC / DMC, 1100V grade																																																																						

Rev No.	Description	Prepared By & Date	Checked By & Date	Approved for Issue By & Date
R00	TECHNICAL SPECIFICATION OF Mini Pillar without Fuses 415 V, 400 A	Yash M. Mane 	Ajay V. Potdar 	Ravindra M. Bhanage 
		22/12/2023	22/12/2023	22/12/2023

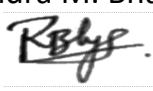

The Tata Power Company Ltd		TECHNICAL SPECIFICATION OF Mini Pillar without Fuses- 415V, 400A
ENSE-DS-2021-R00		Date of Issue: 22/12/2023

21	Incoming Cable provision	4C 300 Sq.mm
22	Outgoing Cable provision	4C 185 Sq.mm
23	Gland plate at panel bottom	MS, Black powder coated, 3mm thick for Multi core cable.
24	Cable termination clearance	300mm minimum from gland plate
25	Earth studs on both side of panel bottom	With M10 galvanized steel nut bolts
26	Panel maximum dimensions in mm Mini Pillar in mm	Width X Depth X Height 650 X 400 X 1270 (or less)
27	Clearance between live parts minimum 25mm(As per IS 13947-Part I)	Phase - phase & Phase - earth
28	Continuous rated operating voltage	440 volt +/- 10%
29	High voltage withstand capacity (Verification as per IS : 8623 (Part 1))	2000 volt at 50 Hz for 1minute
30	Insulation resistance ph-ph & ph-earth	Minimum 10MOhm with 500V Megger
31	Labels & name plates	As per specification
32	Surface preparation for painting	Sand blasting or 7 tank process
33	Painting	Power coated grade A PU min thickness 120 micron
34	Shade	International Orange shade No 592 of IS-5
35	Fluorescent strip	2 Nos. retro reflective sticker 3M or paint (should reflect vehicular lights during night) strips of Yellow colour each of 75 mm width shall be provided on all sides.
36	Panel drawing	Refer drawing
37	Type Test certificate	Type Test to be conducted on one unit of this design.

Rev No.	Description	Prepared By & Date	Checked By & Date	Approved for Issue By & Date
R00	TECHNICAL SPECIFICATION OF Mini Pillar without Fuses 415 V, 400 A	Yash M. Mane 	Ajay V. Potdar 	Ravindra M. Bhanage 
		22/12/2023	22/12/2023	22/12/2023

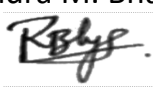

The Tata Power Company Ltd		TECHNICAL SPECIFICATION OF Mini Pillar without Fuses- 415V, 400A
ENSE-DS-2021-R00		Date of Issue: 22/12/2023

5.0	GENERAL CONSTRUCTION	Mini pillar without Fuses - TPN Bus bar with 1 hole (for incomer) & 4 holes (for outgoing).			
		Sr. No.	Parameter	Requirement	
		1	Basic Design	A totally enclosed free standing floor mounted self-supporting metal sheet cubical containing bus-bars connected to distribution feeders.	
		2	Number of Ways	The maximum number of circuits for which the mini pillar without fuses shall be designed: Mini Pillar without Fuses: 5 Way	
		3	Neutral bus	At bottom of panel, with M10 Nut- Bolts for terminating incoming & outgoing Mini Pillar cable neutral circuit	
		4	Earth Bus	Earth strip of 50X6mm GI	
		A. Enclosure:			
		Sr. No.	Parameter	Requirement	
		1	Application	Outdoor type	
		2	Material	Cold Rolled Close Annealed (CRCA) sheet steel - powder coated.	
3	Thickness of enclosure	3 mm. Able to withstand rough weather conditions.			
4	Finishing of enclosure	Pre-treated & powder coating minimum 120 microns at any point of measurement			
5	Design	Compact and enclosure shall be designed to facilitate easy maintenance at a minimum height of 270 mm above FFL			
6	Design at top	Sloping canopy at top so that rain water does not accumulate.			
		Minimum 10 degree slanting slope and extended 50 mm outside			
		Lifting lug- 2 nos. lug welded on top. Eyebolt of suitable sizes shall be provided for lifting arrangements.			
7	Degree of Protection	IP54 suitable for outdoor installation			

Rev No.	Description	Prepared By & Date	Checked By & Date	Approved for Issue By & Date
R00	TECHNICAL SPECIFICATION OF Mini Pillar without Fuses 415 V, 400 A	Yash M. Mane 	Ajay V. Potdar 	Ravindra M. Bhanage 
		22/12/2023	22/12/2023	22/12/2023

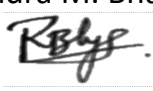

The Tata Power Company Ltd		TECHNICAL SPECIFICATION OF Mini Pillar without Fuses- 415V, 400A
ENSE-DS-2021-R00		Date of Issue: 22/12/2023

				8	Gland plate at panel bottom	Mild Steel 3 mm thick Removable detachable base plate. It shall be possible to temporarily detach the base plate for installation and connection of cables. SS nuts and bolts.						
				9	Fluorescent strip / painting on panel	2 Nos. retro reflective sticker 3M or paint (should reflect vehicular lights during night) strips of yellow colour each of 75 mm width shall be provided on all sides. Paint shall have good colour retention, UV and weather resistant "STICK NO BILLS" to be painted on both sides of the Mini Pillar without Fuses with Black Colour on Yellow Background.						
				10	Dimensions (max)	<table border="1"> <tr> <td>Width</td> <td>Depth</td> <td>Height</td> </tr> <tr> <td>650</td> <td>400</td> <td>1270</td> </tr> </table>	Width	Depth	Height	650	400	1270
				Width	Depth	Height						
				650	400	1270						
				11	Stand	Legs - Iron angle of 40 x 40 x 5 mm at each corner and also hot dipped galvanized Height of leg 250 mm Welded plate at bottom of each leg should have hole of at least 21 mm for fixing of foundation bolt.						
				12	Paint shade	International Orange shade No 592 of IS-5 with minimum 120 microns thickness. Good retention and UV & weather resistant paint.						
				13	Surface preparation for painting	Sand blasting or 7 tank process followed by powder coating						
				14	Foundation Bolts	Required Number of Foundation Bolts to be supplied with the panel.						
				15	Louvers	The panel shall be of dust and vermin proof construction and of self-cooled design with adequate louvers on side's portion. The louvers shall have fine wire mesh. Vermin Proof should be done with gaskets. (Minimum 2 Nos on each sides)						
				16	External hardware	Galvanized steel nut & bolts, Yellow zinc plated with grade 8.8 for Electrical contacts. Other hardware of grade 4.6						
				17	Bolted Covers	Panel Should have internally bolted, removable back cover with handles.						
18	Insulation sheets	All enclosure shall be covered with bolted min 1.5 mm thick SMC/FRP sheets from inside.										

Rev No.	Description	Prepared By & Date	Checked By & Date	Approved for Issue By & Date
R00	TECHNICAL SPECIFICATION OF Mini Pillar without Fuses 415 V, 400 A	Yash M. Mane 	Ajay V. Potdar 	Ravindra M. Bhanage 
		22/12/2023	22/12/2023	22/12/2023

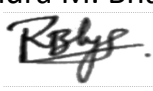

The Tata Power Company Ltd		TECHNICAL SPECIFICATION OF Mini Pillar without Fuses- 415V, 400A
ENSE-DS-2021-R00		Date of Issue: 22/12/2023

		<p>B. Doors:</p> <table border="1"> <thead> <tr> <th>Sr. No.</th> <th>Parameter</th> <th>Requirement</th> </tr> </thead> <tbody> <tr> <td>1</td> <td>Material of door</td> <td>Cold Rolled Close Annealed (CRCA) sheet steel - powder coated.</td> </tr> <tr> <td>2</td> <td>Thickness</td> <td>Thickness - 2.5 mm</td> </tr> <tr> <td>3</td> <td>Type of Door arrangement</td> <td>The door shall be so fitted as to provide the interior with maximum protection from atmospheric conditions. For Mini pillar without Fuses front access Single door</td> </tr> <tr> <td>4</td> <td>Insulation</td> <td>All doors shall be covered with min 1.5 mm thick SMC/FRP sheets.</td> </tr> <tr> <td rowspan="3">5</td> <td rowspan="3">Hinges</td> <td>Minimum 3 Nos. anti-theft hinges for each door. Hinges shall not be visible from outside and should not be removable.</td> </tr> <tr> <td>Material of hinges and screws: Heavy duty stainless steel (SS)</td> </tr> <tr> <td>Hinges shall be of such construction that the doors can be swung open by not less than 120 deg.</td> </tr> <tr> <td>6</td> <td>Engraving</td> <td>SLD shall be engraved & pasted on inside of door</td> </tr> <tr> <td>7</td> <td>Gasket all around sides of enclosure edge</td> <td>The panel shall be provided with gasket all round the perimeter of covers, gland plates, removable covers and doors</td> </tr> <tr> <td>8</td> <td>Door handles</td> <td>On front</td> </tr> <tr> <td>9</td> <td>Paint shade</td> <td>International Orange shade No 592 of IS-5 with minimum 120 microns thickness. Good retention and UV & weather resistant paint. 2 Nos. retro reflective sticker 3M or paint (should reflect vehicular lights during night) strips of yellow colour each of 75 mm width shall be provided on all sides.</td> </tr> <tr> <td>10</td> <td>Surface preparation for painting</td> <td>Sand blasting or 7 tank process followed by powder coating</td> </tr> </tbody> </table> <p>C. Lock:</p> <table border="1"> <thead> <tr> <th>Sr. No.</th> <th>Parameter</th> <th>Requirement</th> </tr> </thead> <tbody> <tr> <td>1</td> <td>Arrangement</td> <td>3 types of lock arrangement: a) Padlock b) Sliding Bolt latch c) Door latch on inner side of door: Tower bolts shall be provided at top and bottom</td> </tr> <tr> <td>2</td> <td>Material of locking mechanism</td> <td>a) For Padlock: Same as that of enclosure b) Sliding Bolt latch of Aluminium c) For Door latch on inner side of door - Stainless</td> </tr> </tbody> </table>	Sr. No.	Parameter	Requirement	1	Material of door	Cold Rolled Close Annealed (CRCA) sheet steel - powder coated.	2	Thickness	Thickness - 2.5 mm	3	Type of Door arrangement	The door shall be so fitted as to provide the interior with maximum protection from atmospheric conditions. For Mini pillar without Fuses front access Single door	4	Insulation	All doors shall be covered with min 1.5 mm thick SMC/FRP sheets.	5	Hinges	Minimum 3 Nos. anti-theft hinges for each door. Hinges shall not be visible from outside and should not be removable.	Material of hinges and screws: Heavy duty stainless steel (SS)	Hinges shall be of such construction that the doors can be swung open by not less than 120 deg.	6	Engraving	SLD shall be engraved & pasted on inside of door	7	Gasket all around sides of enclosure edge	The panel shall be provided with gasket all round the perimeter of covers, gland plates, removable covers and doors	8	Door handles	On front	9	Paint shade	International Orange shade No 592 of IS-5 with minimum 120 microns thickness. Good retention and UV & weather resistant paint. 2 Nos. retro reflective sticker 3M or paint (should reflect vehicular lights during night) strips of yellow colour each of 75 mm width shall be provided on all sides.	10	Surface preparation for painting	Sand blasting or 7 tank process followed by powder coating	Sr. No.	Parameter	Requirement	1	Arrangement	3 types of lock arrangement: a) Padlock b) Sliding Bolt latch c) Door latch on inner side of door: Tower bolts shall be provided at top and bottom	2	Material of locking mechanism	a) For Padlock: Same as that of enclosure b) Sliding Bolt latch of Aluminium c) For Door latch on inner side of door - Stainless
Sr. No.	Parameter	Requirement																																												
1	Material of door	Cold Rolled Close Annealed (CRCA) sheet steel - powder coated.																																												
2	Thickness	Thickness - 2.5 mm																																												
3	Type of Door arrangement	The door shall be so fitted as to provide the interior with maximum protection from atmospheric conditions. For Mini pillar without Fuses front access Single door																																												
4	Insulation	All doors shall be covered with min 1.5 mm thick SMC/FRP sheets.																																												
5	Hinges	Minimum 3 Nos. anti-theft hinges for each door. Hinges shall not be visible from outside and should not be removable.																																												
		Material of hinges and screws: Heavy duty stainless steel (SS)																																												
		Hinges shall be of such construction that the doors can be swung open by not less than 120 deg.																																												
6	Engraving	SLD shall be engraved & pasted on inside of door																																												
7	Gasket all around sides of enclosure edge	The panel shall be provided with gasket all round the perimeter of covers, gland plates, removable covers and doors																																												
8	Door handles	On front																																												
9	Paint shade	International Orange shade No 592 of IS-5 with minimum 120 microns thickness. Good retention and UV & weather resistant paint. 2 Nos. retro reflective sticker 3M or paint (should reflect vehicular lights during night) strips of yellow colour each of 75 mm width shall be provided on all sides.																																												
10	Surface preparation for painting	Sand blasting or 7 tank process followed by powder coating																																												
Sr. No.	Parameter	Requirement																																												
1	Arrangement	3 types of lock arrangement: a) Padlock b) Sliding Bolt latch c) Door latch on inner side of door: Tower bolts shall be provided at top and bottom																																												
2	Material of locking mechanism	a) For Padlock: Same as that of enclosure b) Sliding Bolt latch of Aluminium c) For Door latch on inner side of door - Stainless																																												

Rev No.	Description	Prepared By & Date	Checked By & Date	Approved for Issue By & Date
R00	TECHNICAL SPECIFICATION OF Mini Pillar without Fuses 415 V, 400 A	Yash M. Mane 	Ajay V. Potdar 	Ravindra M. Bhanage 
		22/12/2023	22/12/2023	22/12/2023

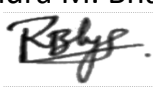

The Tata Power Company Ltd		TECHNICAL SPECIFICATION OF Mini Pillar without Fuses- 415V, 400A
ENSE-DS-2021-R00		Date of Issue: 22/12/2023

		Steel
D. Apron:		
Sr. No.	Parameter	Requirement
1	Material	Cold rolled close annealed (CRCA) sheet steel
2	Design	Bolted Apron shall be provide below the door level of Mini Pillar up to length of 270 mm on all 4 sides and easily removable such that exposed cables are not visible
3	Thickness	3 mm minimum
4	Colour	Matt black colour.
E. Cable Connection:		
Sr. No.	Parameter	Requirement
1	Cable entry direction	Cable entry shall be from bottom of Mini Pillar.
2	Cable termination clearance from gland plate.	300 mm minimum
3	Cable termination	All cable terminations shall be from the front side of the Mini Pillar only
F. Bus- bars:		
Sr. No.	Parameter	Requirement
1	Material grade	Phase & Neutral bus-bars as per IS 5082 - Aluminium grade 19501 (H2).
2	Bus-bar colour coding for R, Y, B & Neutral	Heat shrinkable insulation sleeves (1.1 kV voltage grade and min. Class A insulation class) of colour Red, Yellow, Blue and Black respectively.
3	Bus-bar size (in mm)	1x50x10mm for Phase & Neutral (Al)
4	Bus-bar configuration	Single bus-bars (per phase and neutral) shall be provided.
5	Bus-bar arrangement	Horizontally placed, with R phase bus at top.
6	Bus-bar phase barriers/ Phase separators (R-Y & Y-B)	FRP insulating sheet - (to be placed near to the phase bus-bar) (min 3 mm thickness) shall be provided between bus-bars, so as to ensure that

Rev No.	Description	Prepared By & Date	Checked By & Date	Approved for Issue By & Date
R00	TECHNICAL SPECIFICATION OF Mini Pillar without Fuses 415 V, 400 A	Yash M. Mane 	Ajay V. Potdar 	Ravindra M. Bhanage 
		22/12/2023	22/12/2023	22/12/2023

The Tata Power Company Ltd		TECHNICAL SPECIFICATION OF Mini Pillar without Fuses- 415V, 400A
ENSE-DS-2021-R00		Date of Issue: 22/12/2023

			there is no accidental contact with any live parts. (65 mm width)
7	Bus-bar support insulators	2 nos per phase and neutral of SMC / DMC, 1100 V grade	
8	Neutral Bus-bar	With holes for connecting outgoing cables up to 300 sq.mm.	
9	Cable size	Incoming	Outgoing
		4C x 300 sq.mm.	4C x 185 sq.mm.
G. Panel Configuration:			
Sr. No.	Parameter	Requirement	
1	No. of Incoming	1	
2	No. of outgoing	4	
H. Earthing:			
Sr. No.	Parameter	Requirement	
1	Earth studs	On both sides of panel bottom. Shall be provide with M10 galvanized stell nut bolts washers. The earthing studs shall be welded from inside the enclosure.	
2	Earth bus-bar	To be provided at panel bottom. 50 x 6 mm GI. The earth bus-bar shall be internally connected to two separate earth terminals located outside (on both sides of enclosure). The earth bus-bar shall be located at sufficient height from the gland plate.	
3	Flexible earth connection to doors	Flexible PVC Copper wire 1.5 sq.mm. with gren colour insulation on all doors.	
4	Body Earthing	All hinged doors, Covers, Gland Plates shall be connected to the earth terminal, with the help of green coloured braided copper conductors of adequate size	

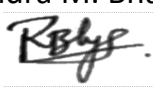
Rev No.	Description	Prepared By & Date	Checked By & Date	Approved for Issue By & Date
R00	TECHNICAL SPECIFICATION OF Mini Pillar without Fuses 415 V, 400 A	Yash M. Mane 	Ajay V. Potdar 	Ravindra M. Bhanage 
		22/12/2023	22/12/2023	22/12/2023

The Tata Power Company Ltd		TECHNICAL SPECIFICATION OF Mini Pillar without Fuses- 415V, 400A
ENSE-DS-2021-R00		Date of Issue: 22/12/2023



5	Neutral Earth link	Earth Bus and Neutral Bus to be shorted with 50 x 6 mm GI link.
---	--------------------	---

I. Danger Board / Branding:

Sr. No.	Parameter	Requirement
1	Danger Board	Danger boards shall be provided in local language also on the on front & rear cover with red background and with white letters.
2	Danger Marking	Front and rear side danger marking with skull and bones with mention of voltage level of 440V AC as per IS 2551.
3	Branding Plate	Separate metallic name plate with Tata Power Logo of Dimension 6*6 Inches as per Annexure 1

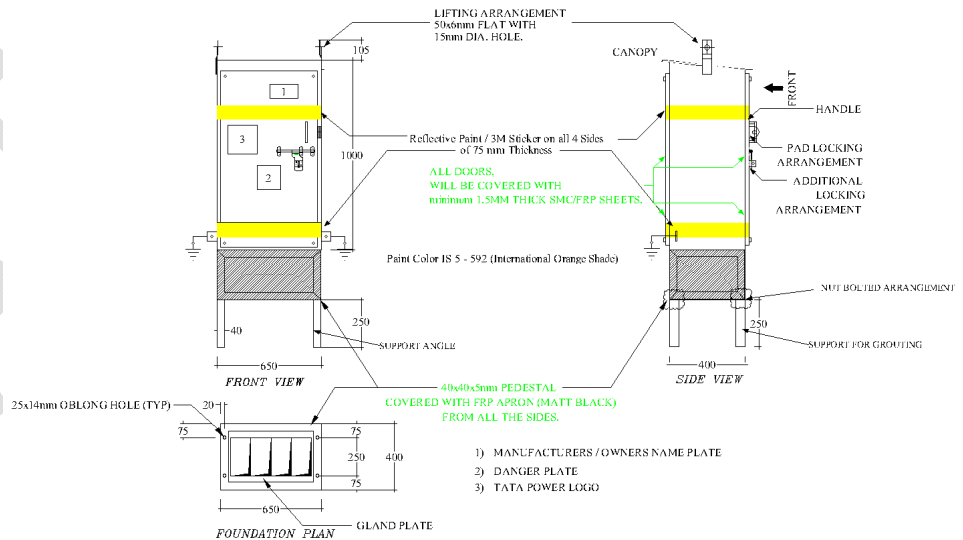
Reference GA DRAWING:

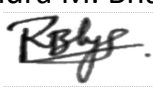

Rev No.	Description	Prepared By & Date	Checked By & Date	Approved for Issue By & Date
R00	TECHNICAL SPECIFICATION OF Mini Pillar without Fuses 415 V, 400 A	Yash M. Mane  22/12/2023	Ajay V. Potdar  22/12/2023	Ravindra M. Bhanage  22/12/2023

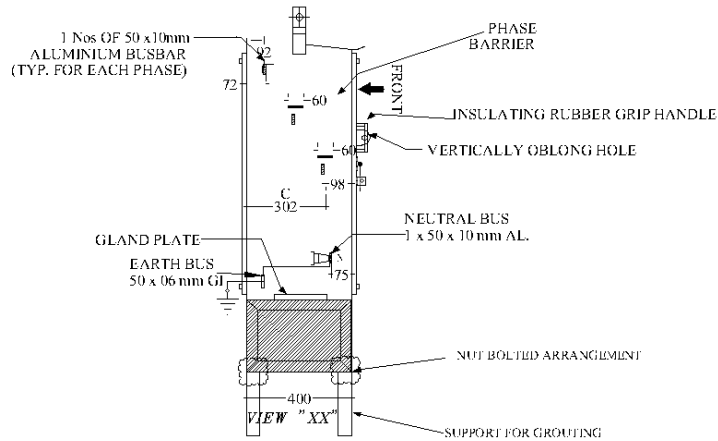
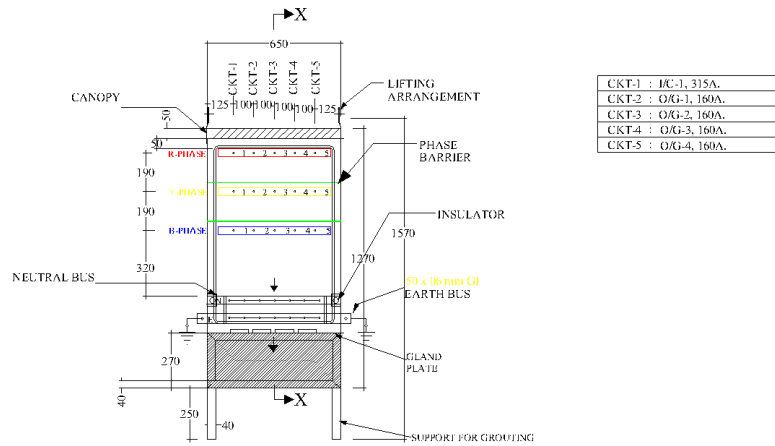



SLD:

Rev No.	Description	Prepared By & Date	Checked By & Date	Approved for Issue By & Date
R00	TECHNICAL SPECIFICATION OF Mini Pillar without Fuses 415 V, 400 A	Yash M. Mane 	Ajay V. Potdar 	Ravindra M. Bhanage
		22/12/2023	22/12/2023	22/12/2023

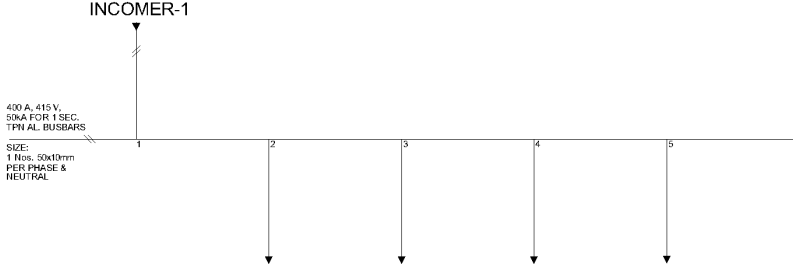

The Tata Power Company Ltd		TECHNICAL SPECIFICATION OF Mini Pillar without Fuses- 415V, 400A
ENSE-DS-2021-R00		Date of Issue: 22/12/2023

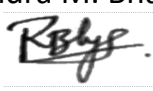
																										
6.0	NAME PLATE & MARKINGS	6.1 Name plate- On front door top left side-showing 1) Purchaser name & PO number. 2) Manufacturer name 3) Month / year of manufacturing 4) 'Property of Tata Power' 5) Mini pillar serial number to be provided.																								
7.0	TESTS	All routine, acceptance & type tests shall be carried out in accordance with the relevant IS/IEC. Following tests shall be necessarily conducted on the 'Sub Feeder Pillar' in addition to others specified in IS/IEC standards. *In case of any conflict on any technical particular, the stricter requirement mentioned in the relevant standard shall be valid.																								
7.1	TYPE TEST	Type test - Only type tested components – Insulators & aluminium bus bar shall be accepted. a. For Enclosure with Bus-bars <table border="1" data-bbox="444 1222 1403 1575"> <thead> <tr> <th>Sr. No.</th> <th>Test</th> <th>Clause No.</th> <th>Reference Standard</th> </tr> </thead> <tbody> <tr> <td>1</td> <td>Verification of temperature-rise limits</td> <td>Clause No 8.2</td> <td>IS 5039</td> </tr> <tr> <td>2</td> <td>Verification of dielectric properties</td> <td>Clause No 8.3</td> <td>IS 5039</td> </tr> <tr> <td>3</td> <td>Verification of short-circuits strength</td> <td>Clause No 8.4</td> <td>IS 5039</td> </tr> <tr> <td>4</td> <td>Verification of clearance and creepage distances</td> <td>Clause No 8.5</td> <td>IS 5039</td> </tr> <tr> <td>5</td> <td>Verification of degree of protection</td> <td>Clause No 8.6</td> <td>IS 5039</td> </tr> </tbody> </table>	Sr. No.	Test	Clause No.	Reference Standard	1	Verification of temperature-rise limits	Clause No 8.2	IS 5039	2	Verification of dielectric properties	Clause No 8.3	IS 5039	3	Verification of short-circuits strength	Clause No 8.4	IS 5039	4	Verification of clearance and creepage distances	Clause No 8.5	IS 5039	5	Verification of degree of protection	Clause No 8.6	IS 5039
Sr. No.	Test	Clause No.	Reference Standard																							
1	Verification of temperature-rise limits	Clause No 8.2	IS 5039																							
2	Verification of dielectric properties	Clause No 8.3	IS 5039																							
3	Verification of short-circuits strength	Clause No 8.4	IS 5039																							
4	Verification of clearance and creepage distances	Clause No 8.5	IS 5039																							
5	Verification of degree of protection	Clause No 8.6	IS 5039																							
7.2	ROUTINE TEST	1. Visual inspection & dimensional check 2. Insulation Resistance test																								

Rev No.	Description	Prepared By & Date	Checked By & Date	Approved for Issue By & Date
R00	TECHNICAL SPECIFICATION OF Mini Pillar without Fuses 415 V, 400 A	Yash M. Mane 	Ajay V. Potdar 	Ravindra M. Bhanage 
		22/12/2023	22/12/2023	22/12/2023

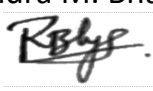

The Tata Power Company Ltd		TECHNICAL SPECIFICATION OF Mini Pillar without Fuses- 415V, 400A
ENSE-DS-2021-R00		Date of Issue: 22/12/2023

		3. HV Test
7.3	ACCEPTANCE TEST	<ol style="list-style-type: none"> 1) Verification of clearance and creepage distance 2) Paint thickness check 3) Paint Shade 4) Wiring checks 5) Insulation resistance test 6) 1 unit from 1st lot shall be tested for Temperature rise test. (Bidder to arrange for the same) 7) HV Test 8) Visual inspection & dimensional check
8.0	TYPE TEST CERTIFICATES	<p>Bidder shall furnish the type test report of 'Mini Pillar of same design' for the tests as mentioned in Clause no.7 of this specification as per reference standards. Complete set of Type Tests shall be conducted at CPRI/ERDA/NABL accredited laboratory. Type test should have been conducted in certified test laboratories during the period not exceeding 10 years from the date of opening the bid. any test report not acceptable or any/all type tests (including additional type tests, if any) not carried out, same shall be carried out without any cost implication to TATA POWER COMPANY.</p> <p>Type tests shall have been conducted in certified Test laboratories during the period not exceeding 10 years from the date of opening the bid. In case if type test conducted beyond 10 years then bidder to certify on letter head of parent OEM that no design change & no manufacturing plant change occurred from type tested product.</p> <p>In the event of any discrepancy in the test reports, i.e. any test report not acceptable or any/all type tests (including additional type tests, if any) not carried out, same shall be carried out without any cost implication to TATA POWER.</p> <p>Bidders shall submit Type Test Undertaking for conducting & submit report with 60 days of Outline Agreement.</p>
9.0	PRE-DESPATCH INSPECTION	<p>The Material shall be subject to inspection by a duly authorized representative of the TATA POWER COMPANY. Inspection may be made at any stage of manufacture at the discretion of the Purchaser and the equipment, if found unsatisfactory as to workmanship or material, the same is liable to rejection. Bidder shall always grant free access to the places of manufacture to TATA POWER COMPANY `s representatives when the work is in progress. Inspection by the TATA POWER COMPANY or its authorized representatives shall not relieve the Bidder of his obligation of furnishing equipment in accordance with the specifications. TATA POWER COMPANY authorized representatives shall have the right to inspect the design, materials and workmanship and to report thereon, at any stage of manufacture, if found necessary. All facilities shall be extended to our representatives for witnessing the tests. Due notice shall be given to us to enable us to depute our representatives for stage inspection.</p> <p>Material shall be dispatched after specific MDCC (Material Dispatch Clearance Certificate) is issued by TATA POWER COMPANY. Five certified copies of all test certificates including type tests, sample test certificates shall be sent to us for our approval prior to dispatch of materials.</p>

Rev No.	Description	Prepared By & Date	Checked By & Date	Approved for Issue By & Date
R00	TECHNICAL SPECIFICATION OF Mini Pillar without Fuses 415 V, 400 A	Yash M. Mane 	Ajay V. Potdar 	Ravindra M. Bhanage 
		22/12/2023	22/12/2023	22/12/2023



The Tata Power Company Ltd		TECHNICAL SPECIFICATION OF Mini Pillar without Fuses- 415V, 400A
ENSE-DS-2021-R00		Date of Issue: 22/12/2023

		<p>Following documents shall be sent along with material</p> <p>a) Test reports b) MDCC issued by TATA POWER COMPANY c) Invoice in duplicate d) Packing list e) Drawings & catalogue f) Delivery Challan g) Other Documents (as applicable)</p>
10.	INSPECTION AFTER RECEIPT AT STORES	<p>The material received at TATA POWER Store will be inspected for acceptance and shall be liable for rejection if found different from the reports of the pre-dispatch inspection and one copy of the report shall be sent to TATA POWER COMPANY.</p> <p>If any deviation or anomaly observed at this stage same need to be rectified by bidder at bidders own cost at earliest.</p> <p>The delay in rectification shall lead to any contractual penalty.</p>
11.0	GUARANTEE	<p>Bidder shall stand guarantee towards design, materials, workmanship & quality of process / manufacturing of items under this contract for due and intended performance of the same, as an integrated product delivered under this contract. In the event any defect is found by the Purchaser up to a period of at least 12 months from the date of commissioning or 24 months from the date of last supplies made under the contract whichever is earlier, Bidder shall be liable to undertake to replace/rectify such defects at its own costs, within mutually agreed time frame, and to the entire satisfaction of the Purchaser, failing which the Purchaser will be at liberty to get it replaced/rectified at Bidder's risks and costs and recover all such expenses plus the Purchaser's own charges (@ 20% of expenses incurred), from the Bidder or from the " Security cum Performance Deposit" as the case may be.</p> <p>In case of GP failure, BA shall report at site within 48 hours from intimation and arrange for rectification of fault within a mutually agreed time. In case rectification at site is not possible then alternative arrangement (replacement) to be made by BA within 15 days of intimation of failure.</p> <p>Bidder shall further be responsible for 'free replacement' for another period of THREE years from the end of the guarantee period for any 'Latent Defects' if noticed and reported by the Purchaser.</p>
12.0	PACKING AND TRANSPORT	<p>Bidder shall ensure that the item covered under this specification shall be packaged for rail/road transport in a manner so as to protect the equipment from damage in transit. The material used for packing shall be environmentally friendly.</p> <p>Packing identification labels- To show purchaser name, PO number, quantity of panels, Panel type, Manufacturer serial number.</p> <p>Handling instruction- To be marked on packing boxes.</p> <p>No single use plastic to be used in packing material. Packing should be done with environment friendly recyclable materials.</p>
13.0	TENDER SAMPLE	Not applicable.

Rev No.	Description	Prepared By & Date	Checked By & Date	Approved for Issue By & Date
R00	TECHNICAL SPECIFICATION OF Mini Pillar without Fuses 415 V, 400 A	Yash M. Mane 	Ajay V. Potdar 	Ravindra M. Bhanage 
		22/12/2023	22/12/2023	22/12/2023

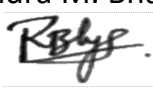

The Tata Power Company Ltd		TECHNICAL SPECIFICATION OF Mini Pillar without Fuses- 415V, 400A
ENSE-DS-2021-R00		Date of Issue: 22/12/2023

14.0	QUALITY CONTROL	<p>The Bidder shall submit with the offer Quality assurance plan indicating the various stages of inspection, the tests and checks which will be carried out on the material of construction, components during manufacture and bought out items and fully assembled component and equipment after finishing. As part of the plan, a schedule for stage and final inspection within the parameters of the delivery schedule shall be furnished.</p> <p>TATA POWER COMPANY shall reserve the sole rights for the type test of a random sample from the lot and in case of any discrepancy or deviation from the Type test certificates submitted along with the Bid; the complete Lot shall be rejected.</p> <p>TATA POWER COMPANY representative or its nominated representative shall have free access to the Bidder's works to carry out inspections.</p> <p>If anything missing in QAP and required as per other clauses of this document, bidder is liable to perform the same without cost implication.</p>
15.0	MINIMUM TESTING FACILITIES	Bidder shall have adequate in-house testing facilities for carrying out all routine tests & acceptance tests as per relevant International / Indian standards
16.0	MANUFACTURING ACTIVITIES	The successful bidder will have to submit first GTP & Drawing with 7 days from placement of outline agreement for approval and complete the approval process within 14 days of outline agreement. The date of Code -2/ Code-1 approval given by TATA Power will be treated as first day for assessment of LD (if applicable).
17.0	SPARES, ACCESSORIES AND TOOLS	Keys of door, 1 set of Fuse Puller with every 30 units.
18.0	DRAWINGS AND DOCUMENTS	<p>Following drawings and documents shall be prepared based on TATA POWER COMPANY specifications and statutory requirements and shall be submitted with the bid.</p> <p>a) Completely filled in Clause wise compliance of this specification b) General description of the equipment and all components including brochures. c) General arrangement drawing. d) Bill of material e) Experience List f) Type test certificates g) Any other technical document, if required</p> <p>All the documents & drawings shall be in English language</p>

Rev No.	Description	Prepared By & Date	Checked By & Date	Approved for Issue By & Date
R00	TECHNICAL SPECIFICATION OF Mini Pillar without Fuses 415 V, 400 A	Yash M. Mane 	Ajay V. Potdar 	Ravindra M. Bhanage 
		22/12/2023	22/12/2023	22/12/2023

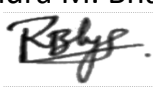

The Tata Power Company Ltd		TECHNICAL SPECIFICATION OF Mini Pillar without Fuses- 415V, 400A
ENSE-DS-2021-R00		Date of Issue: 22/12/2023

19	SCHEDULE "A" GUARANTEED TECHNICAL PARTICULARS:	Clause wise compliance of this specification is to be submitted with bid documents.						
20.0	SCHEDULE "B" DEVIATIONS	<p style="text-align: center;"><u>(TO BE ENCLOSED WITH TECHNICAL BID)</u></p> <p>All deviations from this specification shall be set out by the Bidders, clause by Clause in this schedule. Unless specifically mentioned in this Schedule, the tender shall be deemed to confirm the purchaser's specifications:</p> <table border="1" style="width: 100%; border-collapse: collapse;"> <thead> <tr> <th style="width: 20%;">S.No.</th> <th style="width: 20%;">Clause No.</th> <th style="width: 60%;">Details of deviation with justifications</th> </tr> </thead> <tbody> <tr> <td style="height: 200px;"></td> <td></td> <td></td> </tr> </tbody> </table> <p>We confirm that there are no deviations apart from those detailed above.</p> <p>Seal of the Company: Designation Signature</p>	S.No.	Clause No.	Details of deviation with justifications			
S.No.	Clause No.	Details of deviation with justifications						

Rev No.	Description	Prepared By & Date	Checked By & Date	Approved for Issue By & Date
R00	TECHNICAL SPECIFICATION OF Mini Pillar without Fuses 415 V, 400 A	Yash M. Mane 	Ajay V. Potdar 	Ravindra M. Bhanage 
		22/12/2023	22/12/2023	22/12/2023

The Tata Power Company Ltd		TECHNICAL SPECIFICATION OF Mini Pillar without Fuses- 415V, 400A
ENSE-DS-2021-R00		Date of Issue: 22/12/2023

TATA POWER

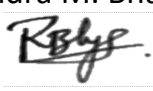
Rev No.	Description	Prepared By & Date	Checked By & Date	Approved for Issue By & Date
R00	TECHNICAL SPECIFICATION OF Mini Pillar without Fuses 415 V, 400 A	Yash M. Mane 	Ajay V. Potdar 	Ravindra M. Bhanage 
		22/12/2023	22/12/2023	22/12/2023

The Tata Power Company Ltd		TECHNICAL SPECIFICATION OF Mini Pillar without Fuses- 415V, 400A
ENSE-DS-2021-R00		Date of Issue: 22/12/2023

Annexure – I

Tata power Branding Name plate -

Separate metallic name plate with Tata Power Logo of Dimension 6*6 Inches in clear font as shown below.

Relationship between the two marks- size

The Tata and Tata Power Marks are always used in conjunction with each other, never appearing in isolation on Tata Power communication.

The height of the letter T of Tata (T-height) is the basic measure for all sizes and proportions.

The rounded measure 2T in height, is separated from the Tata lettering by a distance of 1/2T.

The T height of both, the Tata and the Tata Power Marks is to be the same, except in exceptional cases on approval from the Corporate Communications team.





Relationship between the two marks- positioning

The two marks can appear stacked, which is the preferred placement, or linear, by the side of one another.

Centre aligned - Stacked (Preferred)



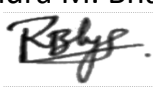

Rev No.	Description	Prepared By & Date	Checked By & Date	Approved for Issue By & Date
R00	TECHNICAL SPECIFICATION OF Mini Pillar without Fuses 415 V, 400 A	Yash M. Mane 	Ajay V. Potdar 	Ravindra M. Bhanage 
		22/12/2023	22/12/2023	22/12/2023

The Tata Power Company Ltd		TECHNICAL SPECIFICATION OF Mini Pillar without Fuses- 415V, 400A
ENSE-DS-2021-R00		Date of Issue: 22/12/2023

Annexure 2: Inspection Testing Plan

- 1) Verification of clearance and creepage distance
- 2) Paint thickness check
- 3) Paint Shade
- 4) Wiring checks
- 5) Insulation resistance test
- 6) 1 unit from 1st lot shall be tested for Temperature rise test. (Bidder to arrange for the same)
- 7) HV Test
- 8) Visual inspection & dimensional check

TATA POWER

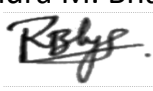
Rev No.	Description	Prepared By & Date	Checked By & Date	Approved for Issue By & Date
R00	TECHNICAL SPECIFICATION OF Mini Pillar without Fuses 415 V, 400 A	Yash M. Mane 	Ajay V. Potdar 	Ravindra M. Bhanage 
		22/12/2023	22/12/2023	22/12/2023